

## COMPARING HEEGAARD SPLITTINGS —THE BOUNDED CASE

HYAM RUBINSTEIN AND MARTIN SCHARLEMANN

ABSTRACT. In a recent paper we used Cerf theory to compare strongly irreducible Heegaard splittings of the same closed irreducible orientable 3-manifold. This captures all irreducible splittings of non-Haken 3-manifolds. One application is a solution to the stabilization problem for such splittings: If  $p \leq q$  are the genera of two splittings, then there is a common stabilization of genus  $5p + 8q - 9$ . Here we show how to obtain similar results even when the 3-manifold has boundary.

### 1. BACKGROUND

In this paper, all manifolds are assumed to be compact and orientable. A *compression body*  $H$  is constructed by adding 2-handles to a (connected surface)  $\times I$  along a collection of disjoint simple closed curves on (surface)  $\times \{0\}$ , and capping off any resulting 2-sphere boundary components with 3-balls. The component (surface)  $\times \{1\}$  of  $\partial H$  is denoted  $\partial_+ H$  and the surface  $\partial H - \partial_+ H$  is denoted  $\partial_- H$ . If  $\partial_- H = \emptyset$  then  $H$  is a *handlebody*. If  $H = \partial_+ H \times I$  then  $H$  is called a *trivial compression body*.

The cores of the 2-handles defining  $H$ , extended vertically down through  $(\partial_+ H) \times I$ , are called a *defining set* of 2-disks for  $H$ . There is a dual picture: A *spine* for  $H$  is a properly imbedded 1-complex  $\Xi$  such that  $H$  deformation retracts to  $\Xi \cup \partial_- H$ . Such a spine can be constructed from a set of defining disks: The arc co-cores of the 2-handles, with the arc ends that lie on 2-spheres coned to the centers of the 3-balls and the other ends extended down to  $\partial_- H$ , are the edges of a spine. The retraction restricts to a map  $\partial_+ H \rightarrow \Xi \cup \partial_- H$  whose mapping cylinder is itself homeomorphic to  $H$ .

A *spanning annulus* in  $H$  is a properly imbedded annulus  $\mathcal{A}$  with one end on each of  $\partial_{\pm} H$ . For  $\mathcal{A}$  a spanning annulus, let  $\partial_{\pm} \mathcal{A} = \mathcal{A} \cap \partial_{\pm} H$ .

A *Heegaard splitting*  $M = A \cup_P B$  of a 3-manifold consists of an orientable surface  $P$  in  $M$ , together with two compression bodies  $A$  and  $B$  into which  $P$  divides  $M$ .  $P$  itself is called the splitting surface. The genus of  $A \cup_P B$  is defined to be the genus of  $P$ . A Heegaard splitting of  $M$  can also be viewed as a handle structure on  $M$ , in which the 1-handles are the co-cores of the defining 2-handles of  $A$  and the 2-handles are the defining 2-handles of  $B$ . A *stabilization* of  $A \cup_P B$  is the Heegaard splitting obtained by adding to  $A$  a regular neighborhood of a proper arc in  $B$  which is parallel in  $B$  to an arc in  $P$ . A stabilization has genus one larger

---

Received by the editors December 21, 1995 and, in revised form, May 8, 1996.

1991 *Mathematics Subject Classification*. Primary 57N10; Secondary 57M50.

Each author was partially supported by a grant from the Australian Research Council.

and, up to isotopy, is independent of the choice of arc in  $B$ , and is the same if the construction is done symmetrically to an arc in  $A$  instead.

Recall the following: If there are meridian disks  $D_A$  and  $D_B$  in  $A$  and  $B$  respectively so that  $\partial D_A$  and  $\partial D_B$  intersect in a single point in  $P$ , then  $A \cup_P B$  can be obtained by stabilizing a lower genus Heegaard splitting. We then say that  $A \cup_P B$  is *stabilized*. If there are meridian disks  $D_A$  and  $D_B$  in  $A$  and  $B$  respectively so that  $\partial D_A$  and  $\partial D_B$  are disjoint in  $P$ , then  $A \cup_P B$  is *weakly reducible*. If there are meridian disks so that  $\partial D_A = \partial D_B$ , then  $A \cup_P B$  is *reducible*. It is easy to see that reducible splittings are weakly reducible and that (except for the genus one splitting of  $S^3$ ) any stabilized splitting is reducible. It is a theorem of Casson and Gordon [CG] that if  $A \cup_P B$  is a weakly reducible splitting then either  $M$  contains an incompressible surface, or  $A \cup_P B$  is reducible. It is a theorem of Haken [Ha] that any Heegaard splitting of a reducible 3-manifold is reducible, and it follows from a theorem of Waldhausen [W] that a reducible splitting of an irreducible manifold is stabilized.

Suppose  $M$  has two splittings  $A \cup_P B$  and  $X \cup_Q Y$ , with  $\partial_- A = \partial_- X$  and  $\partial_- B = \partial_- Y$ . Then it is a classical result that the two splittings are stably equivalent. Generalizing the argument of [RS1], which applies only to closed 3-manifolds, we intend to get a bound on the number of stabilizations required in the case in which both splittings are strongly irreducible. Such strongly irreducible splittings are inevitable, for example, when the 3-manifold has no essential closed surfaces (e.g. the figure 8 knot complement). In the more general case, Johannson has shown [Jo, 31.9] that if  $M$  is Haken, then the number of stabilizations needed grows no more than polynomially with the genus of the two splitting surfaces. On the other hand, no example is known of two irreducible splittings for which each needs more than one stabilization to become equivalent. Indeed, Schultens [Sch] shows that such an example cannot be found among Seifert manifolds, whose Heegaard splittings are most easily understood.

Here is an outline of the proof in the closed case [RS1]:

1. In a 2-parameter positioning of  $P$  and  $Q$  locate a region in which
  - every curve in  $P \cap Q$  is either essential in both surfaces or inessential in both surfaces, and
  - for one of  $P$  or  $Q$ , say  $P$ , there is a path in the region from a positioning in which there is a meridian of  $X$  disjoint from  $P$  to one in which there is a meridian of  $Y$  disjoint from  $P$ .
2. Extend  $P$  to a 2-complex  $K$  by attaching a certain complete collection of meridian disks  $\Delta$  of  $A$  and  $B$ . Then  $M - \eta(K)$  is a collection of balls.
3. In the path of positionings described above locate a point at which every component of  $P \cap Q$  is essential in both surfaces and  $Q \cap K$  contains an entire spine of  $Q$ . That is, every component of  $Q - K$  is a disk.
4. Attach tubes to  $P$  along a collection of arcs in  $(Q - P) \cap \Delta$  which form a spine of  $Q - P$ . Observe that the result is a stabilization  $P^s$  of  $P$ .
5. There is a bound on the number of stabilizations needed, determined by the genus  $q$  of  $Q$  and by the maximal number of pairwise non-parallel  $\partial$ -non-parallel but  $\partial$ -compressible annuli that can lie in  $A$  or  $B$ .
6.  $Q$  can be isotoped so that  $P^s \cap Q$  is a spine of  $Q$ .
7. A spine of  $X$  can be isotoped to lie on  $P^s$ .
8. Then  $q$  stabilizations of  $P^s$  give a stabilization also of  $Q$ .

Steps 1, 5, and 6 are not much more difficult when  $M$  has boundary. They correspond here to Proposition 3.2, sections 5 and 6, and most of 7.4. The difficulty begins in step 2. In order to cut  $A$  and  $B$  into balls one must use not just meridian disks but also a sort of hierarchy, called a *boxing system*, for each compression body. Each boxing system consists of two sets of intersecting annuli. The situation is more difficult partly because the annuli intersect and partly because annuli are not simply connected. The correct positioning of  $Q$  with respect to this boxing system is quite delicate and occupies all of the multipart section 2. The resulting boxing systems will be called *disciplined* with respect to  $Q$ , and the proof that they exist essentially completes step 3.

Because boxing systems are more complicated, it is not immediately clear that attaching tubes along intersection curves with the annuli will necessarily be a stabilization of  $P$ . So step 4, obvious in the closed case, here occupies all of section 4. It turns out that having a disciplined boxing system is what is required here as well. Finally, steps 7 and 8, which establish that the stabilization of  $P$  we have constructed is within  $q$  of being a stabilization of  $Q$ , are also more complicated here. The difficulty is that, unlike the closed case, here we cannot push a spine of  $X$  into the splitting surface  $Q$ , since here any spine of  $X$  has ends attached to  $\partial_0 M$ . The difficulty is resolved in 7.2 by finding an arc which is a vertical spanning arc for both  $X$  and  $A$ . Once again the proof only works because the boxing system is disciplined.

Finally, we repeat a point made in [RS1]: It's expected that a combination of the techniques developed here and those in [RS2] will give an explicit bound on the number of stabilizations required to make any two Heegaard splittings equivalent.

## 2. SURFACES IN COMPRESSION BODIES

### 2.1. Fencing systems, boxing systems, and weakly incompressible surfaces.

**Definition 2.1.** A cutting system in an orientable genus  $g \geq 1$  surface  $S$  is a set  $\mathcal{C}$  of curves in  $S$  which cut  $S$  into annuli or pairs of pants so that each curve in  $\mathcal{C}$  is incident to two distinct components of  $S - \mathcal{C}$ .

**Definition 2.2.** A spine of an orientable surface  $S$  is a finite 1-complex (graph) in  $S$  whose complement is a union of disks (faces). A spine is *special* if it is the union of two cutting systems  $\mathcal{C}$  and  $\mathcal{C}'$  so that each curve from one system meets every curve in the other transversally in at most one point.

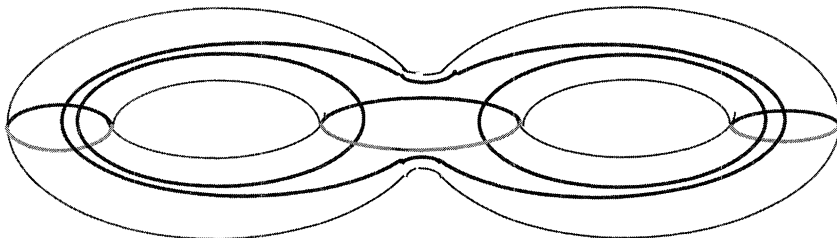

FIGURE 1

Note that for  $g \geq 2$ ,  $3g - 3$  curves in each cutting system can suffice. In this case, each face is a hexagon. See Figure 1.

**Definition 2.3.** Suppose  $H$  is a compression body,  $\Delta$  is a collection of defining disks and  $\mathcal{C}$  is a cutting system of  $\partial_-(H)$ . Then the union  $\mathcal{F}$  of  $\Delta$  and  $(\mathcal{C} \times I) \subset (\partial_-(H) \times I) = H - \Delta$  is called a *fencing system* for  $H$  based on  $\mathcal{C}$  if each disk in  $\Delta$  is incident to two distinct components of  $H - \mathcal{F}$ .

Suppose  $\mathcal{C}'$  is a second cutting system of  $\partial_-(H)$  which, together with  $\mathcal{C}$  forms a special spine. Then the union of  $\mathcal{F}$  and  $(\mathcal{C}' \times I) \subset (\partial_-(H) \times I) = H - \Delta$  is called a *boxing system* for  $H$  based on the standard spine  $\mathcal{C} \cup \mathcal{C}'$ . The annuli in  $\mathcal{C} \times I$  are called primary annuli or fences, and the annuli in  $\mathcal{C}' \times I$  are called secondary annuli. The complementary components of  $\mathcal{F}$  in  $H$  are called the parcels of the fencing system, and the complementary components of  $\mathcal{B}$  are called the boxes of the boxing system. The spanning arcs  $\Gamma$  of  $H$  which are the intersections of primary and secondary annuli are called the posts of the boxing system.

Note that each parcel is a handlebody (possibly a ball) of genus  $\leq 2$  and each box is homeomorphic to a ball. See Figure 2.

**Definition 2.4.** A properly imbedded oriented surface  $(Q, \partial Q) \subset (M, \partial M)$  is a splitting surface if  $M$  is the union of two 3-manifolds  $X$  and  $Y$  along  $Q$  so that  $\partial X$  induces the given orientation on  $Q$  and  $\partial Y$  induces the opposite orientation. A compressing disk for  $Q$  (in  $X$ ) is called a meridian disk (in  $X$ ) and its boundary a meridian curve (for  $X$ ). More generally, a near meridian disk in  $X$  (resp.  $Y$ ) is a disk  $D \subset M$  transverse to  $Q$  so that  $\partial D \subset Q$  is essential in  $Q$ , all components of  $\text{interior}(D) \cap Q$  are inessential in  $Q$ , and the component of  $D - Q$  adjacent to  $\partial D$  lies in  $X$  (resp.  $Y$ ).

A splitting surface  $Q$  is called strongly compressible if there are meridian disks in  $X$  and  $Y$  with disjoint boundaries. If there are no such disks,  $Q$  is called weakly incompressible.  $Q$  is called reducible if there are meridian disks in  $X$  and  $Y$  whose boundaries meet at a single point in  $Q$ .

Two things to note: The boundary of a near meridian disk is a meridian curve. With the sole exception of an unknotted torus lying in a ball in  $M$ , any connected reducible surface is strongly compressible.

For examples of weak incompressibility, suppose  $X \cup_Q Y$  is a strongly irreducible Heegaard splitting of a manifold  $M$ . Then  $Q$  is weakly incompressible. Moreover, if  $M = A \cup_P B$  is another Heegaard splitting and each curve of  $P \cap Q$  is incompressible in both surfaces, then  $Q \cap A \subset A$  may or may not be compressible, but it's always weakly incompressible.

**Proposition 2.5** (The swapping lemma). *Suppose  $(Q, \partial Q) \subset (M, \partial M)$  is a weakly incompressible splitting surface compressing both to  $X$  and to  $Y$ , and  $(T, \partial T) \subset (M, Q)$  is a proper planar surface with boundary components  $\partial T_0, \dots, \partial T_m, m \geq 1$ , so that*

1.  $\text{interior}(T) \subset X$ ,
2. each curve  $\partial T_i, 1 \leq i \leq m$ , is a meridian curve for  $Y$ , and
3.  $\partial T_0$  is essential in  $Q$ .

*Then there is a planar surface  $U$  in  $Q$  itself, with  $\partial U$  the union of  $\partial T_0$  and some copies of some of the  $\partial T_i, 1 \leq i \leq m$ .*

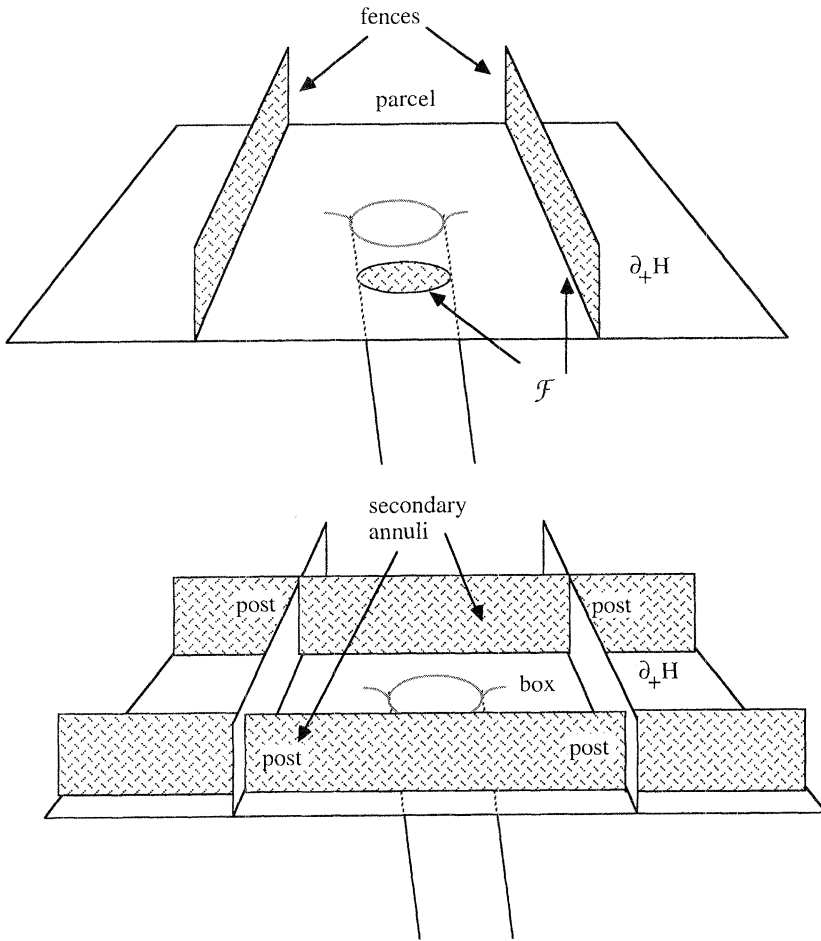

FIGURE 2

*Proof.* Since  $Q$  is weakly incompressible, yet compresses both into  $X$  and into  $Y$ , all meridian curves of both  $X$  and  $Y$  lie on a single component  $Q_0$ . Compress  $Q_0$  into  $Y$  along the meridian disks  $D_i, 1 \leq i \leq m$ , bounded by  $(\partial T)_i, 1 \leq i \leq m$ , and call the result  $S_Y \subset Y$ . Let  $X^+ \subset M$  denote the 3-manifold obtained from  $X$  by attaching the corresponding 2-handles. Somewhat similarly, let  $S_X \subset X$  denote the surface obtained by maximally compressing  $Q_0$  into  $X$ . Then the region between  $S_X$  and  $S_Y$  in  $X^+$  is obtained by attaching 2-handles to both sides of a collar  $Q_0 \times I$  of  $Q_0$ . Since  $Q_0$  is weakly incompressible, it follows as in [CG] that both  $S_X$  and  $S_Y$  are incompressible in  $X^+$ .

The choice of  $D_i$  guarantees that  $T$  extends to a disk  $T^+$  in  $X^+$  with  $\partial T^+ = \partial T_0$ . Since  $S_X$  is incompressible in  $X^+$ ,  $T^+$  can be isotoped to be disjoint from  $S_X$  and so lies in the region between  $S_X$  and  $S_Y$ . Since  $\partial T_0$  lies in  $Q_0$  and is disjoint from each  $\partial T_i, 1 \leq i \leq m$ , we may consider  $\partial T_0 \subset S_Y$ . Then [CG] implies that  $\partial T_0$  is inessential in  $S_Y$ , as required.  $\diamond$

2.2. Organizing intersections with fencing and boxing systems.

**Definition 2.6.** Suppose  $\mathcal{F}$  is a fencing system for a compression body  $H$  and  $(Q, \partial Q) \subset (H, \partial_+ H)$  is a weakly incompressible splitting surface that is in general position with respect to  $\mathcal{F}$ . Then  $\mathcal{F}$  is an  $X$ -set (resp.  $Y$ -set) with respect to  $Q$  if some component of the boundary of  $Q - \mathcal{F}$  is a meridian curve of  $X$  (resp.  $Y$ ).

Similarly, a boxing system  $\mathcal{B}$  is an  $X$ -set ( $Y$ -set) if some component of the boundary of  $Q - \mathcal{B}$  is a meridian curve of  $X$  (resp.  $Y$ ).

**Lemma 2.7.**  $\mathcal{F}$  is an  $X$ -set (resp.  $Y$ -set) with respect to the weakly incompressible splitting surface  $Q$  if and only if there is a parcel  $W$  so that  $\partial W$  contains a near meridian disk  $D$  for  $X$  (resp.  $Y$ ). A similar statement holds for boxing systems, with “boxes” replacing “parcels”.

*Proof.* Suppose  $\mathcal{F}$  is an  $X$ -set, so a component  $q$  of  $Q - \mathcal{F}$  has a boundary curve  $c$  which also bounds a meridian disk in  $X$ . Let  $W$  be the parcel in which  $q$  lies.  $W$  is a genus  $\leq 2$  handlebody and the surface  $T = \partial W - \partial M$  (in which  $c$  lies) is a sphere, annulus, or pair of pants with  $\pi_1(T) \rightarrow \pi_1(M)$  injective. Since  $c$  bounds a disk in  $X \subset M$ ,  $c$  bounds a disk in  $T$ . (See Figure 3.) Of all components of  $Q \cap T$  which, like  $c$ , are essential in  $Q$  but bound a disk in  $T$ , let  $c'$  be the innermost. Then an innermost disk argument shows that  $c'$  bounds a meridian disk for either  $X$  or  $Y$ , and it can't be the latter, by weak incompressibility of  $Q$ . Take for  $D$  the disk in  $\partial W$  bounded by  $c'$ .

Conversely, if such a disk  $D$  exists, then  $\partial D$ , which lies on the boundary of  $(Q \cap W) \subset (Q - \mathcal{F})$ , is a meridian curve since the component of  $D - Q$  containing  $\partial D$  extends to a disk lying entirely in  $X$ .  $\diamond$

Since  $Q$  is weakly incompressible, no boxing system or fencing system can be simultaneously an  $X$ -set or  $Y$ -set, nor can there simultaneously be a boxing system built on a fencing system, for which one system is an  $X$ -set and the other a  $Y$ -set. Generalizing this somewhat, we have:

**Lemma 2.8** (Saddle-box lemma). *Suppose  $\mathcal{B}$  is a boxing system so that  $B_+$  and  $B_-$  are two boxes with common side  $E$ . Suppose  $Q$  is weakly incompressible, has no unknotted torus components, and is in general position with respect to  $\mathcal{B}$  except for a saddle singularity in the interior of  $E$ . Let  $Q_\pm$  denote the surfaces obtained by pushing the saddle singularity into  $B_\pm$  respectively. If  $\mathcal{B}$  is an  $X$ -set with respect to  $Q_-$  then it's not a  $Y$ -set with respect to  $Q_+$ .*

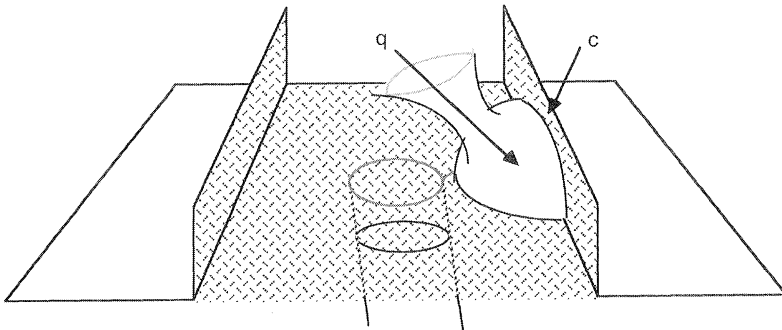

FIGURE 3

(Saddle-fence lemma). Suppose  $B_{\pm}$  as above lie in different parcels  $P_{\pm}$  of a fencing system  $\mathcal{F}$  in  $\mathcal{B}$ . Suppose  $\mathcal{B}$  is an  $X$ -set with respect to  $Q_-$ , and  $\mathcal{F}$  is a  $Y$ -set with respect to  $Q_+$ . Then there is a surface  $Q'$  in  $M$  with the following properties:

1.  $Q'$  is obtained from  $Q_-$  by compressing a meridian disk of  $X$  lying in  $B_-$ .
2. In Figure 4,  $Q_-$  is obtained from  $Q'$  by 1-surgery on an arc. The core of the arc is “unknotted”, i.e. parallel in  $Y \cap B_-$  to an arc that spans an essential annulus component of  $\partial P_+ - Q_-$ .
3.  $\mathcal{B}$  is neither an  $X$ -set nor a  $Y$ -set with respect to  $Q'$ .

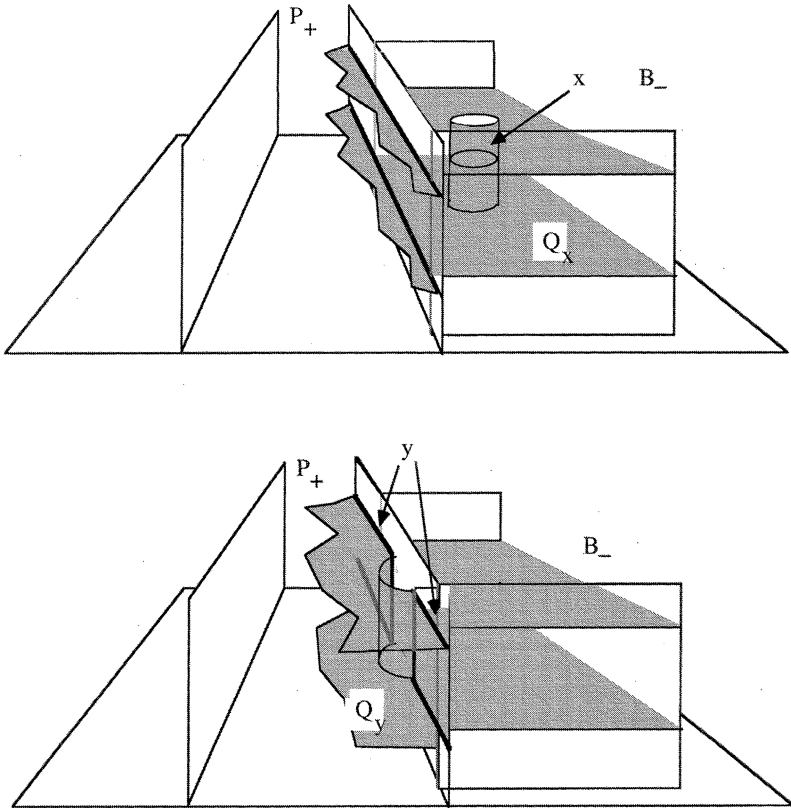

FIGURE 4

*Proof.* Let  $x$  be the boundary component of  $Q_- - \mathcal{B}$  which is a meridian of  $X$ , and let  $Q_x$  denote the component of  $Q_- - \mathcal{B}$  on which it lies. Similarly let  $y$  be the boundary component of  $Q_+ - \mathcal{B}$  or  $Q_+ - \mathcal{F}$  which is a meridian of  $Y$ , and  $Q_y$  the component of  $Q_+ - \mathcal{B}$  or  $Q_+ - \mathcal{F}$  (as relevant) on which it lies. First note that  $Q_x$  must lie in  $B_-$ , for otherwise  $x$  would persist in the interior of  $Q_+ - \mathcal{B}$ , contradicting weak incompressibility. Next note that each component of  $Q_+ \cap \partial B_-$  must be inessential in  $Q$ , for otherwise, since  $\partial B_-$  is a sphere, one would bound a meridian disjoint from both  $x$  and  $y$ , violating weak incompressibility. So passing through the saddle cuts an arc from the essential component  $Q_x$  and turns it into

an inessential component. It follows that  $Q_x$  is an annulus, and, passing through the saddle singularity, cuts it by a spanning arc.

If  $\mathcal{B}$  is a  $Y$ -set for  $Q_+$  we could apply the same argument to the component  $Q_y$  in  $B_+$  and deduce that it's also an essential annulus whose core curve bounds a meridian of  $Y$  and for which the saddle corresponds to a spanning arc. But this would imply that  $Q$  is reducible. The contradiction proves the saddle-box lemma.

For the saddle-fence lemma, let  $Q'$  be the surface obtained from  $Q_-$  by compressing  $x \subset Q_x$  into  $X - \mathcal{B}$ . If  $\mathcal{F}$  is a  $Y$ -set for  $Q_+$ , the same contradiction would arise as above if the band in  $Q_+$  corresponding to the saddle point had only one end on  $y$ , or if it had both ends on  $y$  and the band was inessential in  $\partial P_+$ . So passing the band into  $B_-$  bands  $y$  to itself in the fence, creating two parallel essential curves in  $\partial P_+$ . The co-core  $\gamma$  of this band intersects  $x$  in one point, so  $Q$  can be recovered from  $Q'$  by doing 1-surgery along the arc  $\gamma$ .

Finally, note that if  $\mathcal{B}$  is a  $Y$ -set for  $Q'$  then it would have been a  $Y$ -set for  $Q_-$ , and if  $\mathcal{B}$  is an  $X$ -set for  $Q'$  then it would have been an  $X$ -set for  $Q_+$ . Either contradicts weak incompressibility of  $Q$ .  $\diamond$

Let  $(Q, \partial Q) \subset (H, \partial_+ H)$  be a properly imbedded surface in the compression body  $H$  so that  $\partial Q$  is essential both in  $\partial_+ H$  and in  $Q$ .

**Definition 2.9.** A fencing system  $\mathcal{F}$  for  $H$  is disciplined with respect to  $Q$  if

1.  $Q$  is in general position with respect to  $\mathcal{F}$ , and
2. no component of  $Q \cap \mathcal{F}$  is an inessential closed curve in  $\mathcal{F}$ .

**Definition 2.10.** A boxing system  $\mathcal{B}$  is disciplined with respect to  $Q$  if the following conditions hold:

1.  $Q$  is in general position with respect to  $\mathcal{B}$ .
2. The fencing system  $\mathcal{F}$  of  $\mathcal{B}$  is disciplined with respect to  $Q$ .
3. In any primary annulus (fence)  $F$  of  $\mathcal{F}$ , each post is disjoint from the arc components of  $Q \cap F$  and intersects each closed curve in  $Q \cap F$  exactly once.
4. In any secondary annulus  $\mathcal{A}$  each closed curve in  $Q \cap \mathcal{A}$  is essential in  $\mathcal{A}$  and intersects each post in  $\mathcal{A}$  precisely once. (That is, these curves are monotonic in  $\mathcal{A}$ .) (See Figure 5.)
5.  $Q \cap \mathcal{B}$  is a spine of  $Q$ .

As a warm-up lemma we have:

**Lemma 2.11.** *Suppose  $(Q, \partial Q) \subset (H, \partial_+ H)$  is an incompressible splitting surface in a compression body  $H$ . Then any special spine  $\mathcal{C} \cup \mathcal{C}'$  in  $\partial_- H$  is the base of a disciplined boxing system in  $H$  with respect to  $Q$ .*

*Proof.* Construct first any fencing system  $\mathcal{F}$  based on  $\mathcal{C}$ . Since  $Q$  is incompressible, any closed curves in  $Q \cap \mathcal{F}$  which are inessential in  $\mathcal{F}$  are inessential also in  $Q$  and so can be removed by an isotopy. Thus  $\mathcal{F}$  is made disciplined. We can also suppose that no subannulus of  $\mathcal{F}$  is parallel to a subannulus of  $Q$ , by repeatedly isotoping away innermost such pairs. In each fence  $F \subset \mathcal{F}$  choose a family of spanning arcs of the fence, each with one end on a point of  $(F \cap \mathcal{C}') \subset \partial_- F$ , each intersecting each essential curve in  $Q \cap F$  in exactly one point, and each avoiding the arc components of  $Q \cap F$  (which have both ends on  $\partial_+ F$ ). Let  $\Gamma$  be the union of all these spanning arcs in  $\mathcal{F}$ . In any parcel  $P$  of  $H - \mathcal{F}$  the union of a segment of  $\mathcal{C}' \cap \partial P$  and the two arcs of  $\Gamma$  at its ends can be completed by an arc in  $\partial_+ H$  to give a square bounding a disk  $E$  in  $P$ . The union of all such disks  $E$  then gives a fencing system



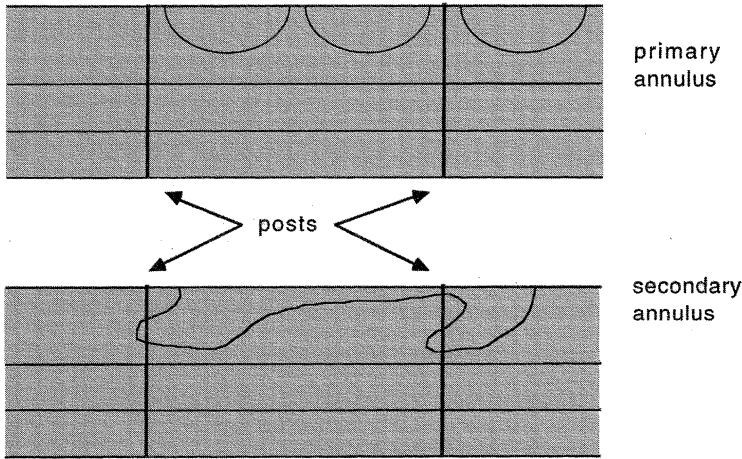

FIGURE 5

on  $C'$  which, together with  $\mathcal{F}$ , makes a boxing system  $\mathcal{B}$  for  $H$ . If we isotope the rectangles  $E$  to eliminate all closed (hence inessential) curves of intersection with  $Q$ , it's easy to verify that  $\mathcal{B}$  is disciplined. Only 2.10.4 requires a slight argument: If in a secondary annulus  $\mathcal{A}$  a closed curve of  $Q \cap \mathcal{A}$  intersects a post more than once, then there is a subsegment  $\gamma$  of a post to which a component  $q$  of  $Q - \mathcal{F}$   $\partial$ -compresses. But this  $\partial$ -compression converts the essential subannulus  $\phi$  of  $\mathcal{F} - Q$  spanned by  $\gamma$  into a disk. Since the disk can't be a compressing disk for  $Q$ , it must bound a disk in  $Q$ . But this means that  $q$  is an annulus parallel to  $\phi$ , contradicting our construction.  $\diamond$

It will be important to understand how the properties of being an  $X$ - or  $Y$ -set or being disciplined may change with different choices of fencing or boxing systems. Suppose  $\mathcal{F}$  and  $\mathcal{F}'$  are two fencing systems based on  $\mathcal{C}$ . It's easy to see that one can move between them by a series of isotopies rel  $\mathcal{C}$  adding or deleting a disk element parallel to another disk element, and band-summing an annulus or disk element to another disk element. Call such a series of operations a *bandotopy*. A bandotopy will be expressed as a series  $(g^1, \dots, g^n)$ , where each  $g^j$  is a proper general position isotopy of a fencing system  $\mathcal{F}^j$  in  $H$ , and  $g_1^j(\mathcal{F}^j)$  differs from  $g_0^{j+1}(\mathcal{F}^{j+1})$  by either the deletion or addition of a parallel disk, or a band-sum of one element to a parallel copy of a different disk element. Additions of parallel disks are sometimes needed just to ensure that no parcel of the fencing system is incident to both sides of the same disk (cf. 2.3).

We make a similar definition for boxing systems  $\mathcal{B}$  and  $\mathcal{B}'$  which are both based on  $\mathcal{C}'$  and which include a fixed set of posts in the same fencing system  $\mathcal{F}$ . Then we can move between  $\mathcal{B}$  and  $\mathcal{B}'$  by isotoping the squares  $\mathcal{B} - \mathcal{F}$  in the parcels of  $\mathcal{F}$  and banding the cells to copies of disk elements of  $\mathcal{F}$ . Each square is kept fixed on three sides: the two posts and the subarc of  $\mathcal{C}'$  in its boundary.

Given a bandotopy  $(g_1, \dots, g_n)$  of a fencing or boxing system, it's often convenient to think of the parameter of the isotopy  $g_j$  running between  $(j-1)/n$  and  $j/n$ . Then we can think of the bandotopy as parameterized by  $s \in [0, 1]$  with "singular"

points at each  $j/n, 1 \leq j \leq n$ , when a band-sum takes place or a disk is added or deleted.

When considering how properties of a fencing or boxing system change during a bandotopy, the first observation is that banding an annulus or a disk element of a fencing system  $\mathcal{F}$  to a disk element, or adding or deleting a disk parallel to a disk element, only adds, removes or moves arc components of  $Q \cap \mathcal{F}$ , but not simple closed curves. So there is no effect on whether  $\mathcal{F}$  is disciplined. The effect on  $Q - \mathcal{F}$  is to add, delete, or move disk components, so there is no effect on whether  $\mathcal{F}$  is an  $X$ - or  $Y$ -set.

So any change in these properties happens during the isotopy part of a bandotopy, necessarily when there is either a tangency point of  $Q$  with  $\mathcal{F}$  or of  $\partial Q$  with  $\partial \mathcal{F}$ . A center tangency of  $Q$  with  $\mathcal{F}$  or a “half-center” tangency of  $\partial Q$  with  $\partial \mathcal{F}$  will only introduce or delete inessential curves of intersection or arcs of intersection; so, although the former may make  $\mathcal{F}$  no longer disciplined, neither alters the property of being an  $X$ - or  $Y$ -set. If there is a half-saddle tangency of  $\partial \mathcal{F}$  with  $\partial Q$ , an arc of intersection can become a closed curve. In one parcel incident to the tangency point there is no change in the topology of  $Q - \mathcal{F}$ , and in the other a band is added or deleted. The upshot is that such a half-saddle may change whether  $\mathcal{F}$  is disciplined and whether or not  $\mathcal{F}$  is an  $X$ - or  $Y$ -set, but, because only the topology within a single parcel is changed, it can’t change an  $X$ -set to a  $Y$ -set or vice versa. Finally, a saddle tangency between  $Q$  and  $\mathcal{F}$  may change an  $X$ -set into a  $Y$ -set or vice versa. But we conclude that this is the only way such a change can happen. Similar remarks apply to a bandotopy of a boxing system with fixed fences.

### 2.3. When some fencings are straight.

**Definition 2.12.** Suppose  $(Q, \partial Q) \subset (H, \partial_+ H)$  is a weakly incompressible splitting surface in a compression body  $H$ . A fencing system  $\mathcal{F}$  in  $H$  is straight (for  $Q$ ) if  $H - \mathcal{F}$  contains both a meridian of  $X$  and a meridian of  $Y$  (necessarily in the same parcel of  $H - \mathcal{F}$ ).

**Proposition 2.13.** *Suppose  $(Q, \partial Q) \subset (H, \partial_+ H)$  is a weakly incompressible splitting surface in a compression body  $H$ . Suppose there is a fencing system  $\mathcal{F}$  and a secondary annulus  $\mathcal{A}$  in a boxing system  $\mathcal{B}$  extending  $\mathcal{F}$  for which*

1.  $\mathcal{F}$  is disciplined and straight,
2. no component of  $Q - \mathcal{F}$  is an annulus with both ends incident to the same side of the same fence, and
3. no closed component of  $Q \cap \mathcal{A}$  is disjoint from the set  $\Gamma$  of posts of  $\mathcal{B}$ .

*Then each closed component of  $Q \cap \mathcal{A}$  that is essential in  $\mathcal{A}$  is monotonic with respect to  $\Gamma \cap \mathcal{A}$ .*

*Proof.* Suppose some closed component  $c$  of  $Q \cap \mathcal{A}$  that is essential in  $\mathcal{A}$  intersects a component of  $\Gamma$  more than once. Then  $c$  contains a subarc  $\alpha$  which is parallel to a subarc  $\gamma$  of  $\Gamma$  via a disk (called a  $\partial$ -compressing disk) whose interior is disjoint from  $\Gamma$  and from  $c$ . If the interior is disjoint from  $Q$  as well, we say  $\alpha$  is “outermost”. We distinguish two cases:

*Case 1.* All  $\partial$ -compressing disks for  $c$  are outermost. In this case, at least one  $\partial$ -compressing disk lies entirely in  $X$  and another entirely in  $Y$ . Each disk defines a  $\partial$ -compression of  $Q$  to  $\mathcal{F}$  that yields a meridian of  $X$  and  $Y$  respectively, since no

component of  $Q - \mathcal{F}$  is a  $\partial$ -parallel annulus. If the subannuli of  $\mathcal{F}$  to which they  $\partial$ -compress  $Q$  were adjacent in  $\mathcal{F}$ , then the meridians could be pushed into different parcels. If they are not adjacent, then, after the  $\partial$ -compressions, the meridians would be disjoint. Either possibility contradicts weak incompressibility.

*Case 2.* Some  $\partial$ -compressing disk contains other arcs of  $Q \cap \mathcal{A}$ . Then there is a subarc  $\beta$  of  $Q \cap \mathcal{A}$  parallel to a subarc  $\gamma$  of  $\Gamma$ , and the  $\partial$ -compressing disk  $E$  between them contains only outermost arcs  $\alpha_1, \dots, \alpha_m$  in  $Q$ .  $\partial$ -compress first the  $\alpha_i$  and then  $\beta$  to  $\mathcal{F}$ . The result is a planar surface  $T$  in  $\mathcal{F}$  each of whose boundary components are essential in  $Q$ , by assumption 2. The surface  $T$  lies entirely in  $X$  or  $Y$ , say  $X$ , and all but the outermost component  $\partial_0 T$  is a meridian of  $Y$ . Then 2.5 shows there is a similar planar surface  $U$  in  $Q$  itself.

Now undo the  $\partial$ -compressions and examine the effect in  $Q$ . This is most easily described in the surface  $Q^-$  obtained by compressing  $Q$  along  $\partial U - \partial_0 T$ . In  $Q^-$ ,  $U$  is part of a disk whose interior contains disks bounded by the closed curves  $\partial U - \partial_0 T$ . When the  $\partial$ -compressions are undone, a band is attached to  $\partial_0 T$  in  $Q^- - U$  to give an annulus  $B$  bounded by the curves in  $Q \cap \mathcal{F}$  which are at the ends of  $\beta$ . Similar bands are attached to the disks bounded by  $\partial U - \partial_0 T$ , giving subannuli  $A_i$  of  $B$  which are essential, hence parallel to the core of  $B$ , since all curves in  $Q \cap \mathcal{F}$  are essential in  $Q$ . Then each component of the complement of the  $A_i$  in  $B$  is a subannulus of  $Q$  incident at both ends to the same side of the component of  $\mathcal{F}$  that contains  $\gamma$ . This contradicts our assumption 2. (See Figure 6.)  $\diamond$

**Proposition 2.14.** *Suppose  $(Q, \partial Q) \subset (H, \partial_+ H)$  is a weakly incompressible splitting surface, with no closed component, in a compression body  $H$ , and let  $C \cup C'$  be a special spine in  $\partial_- H$ . Suppose further that  $C$  is the base of a disciplined and straight fencing system for  $H$ . Then there is such a fencing system  $\mathcal{F}$  so that*

1. *no component of  $Q - \mathcal{F}$  is an annulus with both ends incident to the same side of the same fence, and*
2.  *$\mathcal{F}$  extends to a disciplined boxing system for  $Q$  based on  $C \cup C'$ .*

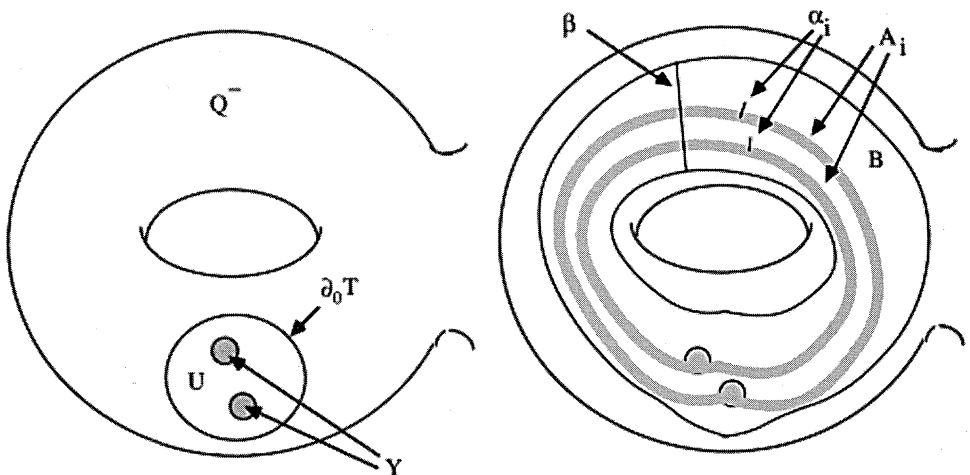

FIGURE 6

*Proof.* Suppose  $W$  is a parcel for  $\mathcal{F}$  and suppose there's an annulus in  $W$  with both ends on the same fence  $F$ . It's then parallel in  $W$  to a subannulus of  $F$ , since  $F$  is incompressible in  $W$ . The annulus can therefore be removed by an isotopy of  $F$  without affecting our assumptions about  $\mathcal{F}$ . Indeed, such an isotopy can introduce but not remove a meridian disk in  $H - \mathcal{F}$ . This establishes the first condition.

As in 2.11,  $\mathcal{F}$  extends to a boxing system based on  $\mathcal{C} \cup \mathcal{C}'$  for which the posts  $\Gamma$  satisfy the conditions of 2.10. We now exploit the ambiguity in the construction of this boxing set. Let  $W$  be the parcel that contains both a meridian of  $X$  and a meridian of  $Y$  (which exists since  $\mathcal{F}$  is straight) and let  $E$  denote the collection of (two or three) squares  $\mathcal{B} \cap W$  in which the secondary annuli intersect  $W$ . Since there are meridians of  $X$  and  $Y$  in  $W$ , there is a choice  $E_0$  of squares in  $\mathcal{B} \cap W$  so that  $E_0 \cap Q$  contains a meridian of  $X$  and a choice  $E_1$  so that  $E_1 \cap Q$  contains a meridian of  $Y$ . (To see this, shrink the relevant meridian disk very small so that a neighborhood of it looks like the tubular neighborhood of an arc. Then choose a square that crosses the arc transversally.) There is a bandotopy  $E_s, 0 \leq s \leq 1$ , from  $E_0$  to  $E_1$ . Let  $\mathcal{B}_s$  denote its (constant) extension to the rest of  $\mathcal{B}$ . For any generic value of  $s$ , let  $\mathcal{F}'_s$  denote the fencing system for  $H$  consisting of the disk components of  $\mathcal{F}$  and the secondary annuli of  $\mathcal{B}_s$ . Let  $\sigma_X \subset [0, 1]$  (resp.  $\sigma_Y$ ) denote the set of generic  $s \in [0, 1]$  so that either  $\mathcal{B}_s$  or  $\mathcal{F}'_s$  is an  $X$ -set (resp.  $Y$ -set). Then  $0 \in \sigma_X$  and  $1 \in \sigma_Y$ . Notice that  $\sigma_X \cap \sigma_Y = \emptyset$  by weak incompressibility.

Suppose a generic point  $s_0$  is disjoint from both  $\sigma_X$  and  $\sigma_Y$ . Then components of  $Q \cap \mathcal{F}'_{s_0}$  that are inessential circles in  $Q$  and disjoint from  $\mathcal{F}$  can be removed by an isotopy of  $\mathcal{F}'_{s_0}$  rel  $\mathcal{F}$ . An outermost arc argument then shows, from the fact that  $\mathcal{F}$  is disciplined, that any closed component of  $Q \cap \mathcal{F}'_{s_0}$  is essential in  $Q$ . If any closed component of  $Q \cap \mathcal{F}'_{s_0}$  were inessential in  $\mathcal{F}'_{s_0}$  then it would be a meridian curve, contradicting our choice of  $s_0$ . Then every condition except monotonicity of essential curves in secondary annuli is automatic. Monotonicity follows from 2.13.

Finally, suppose some  $s_0$  were in  $\overline{\sigma_X} \cap \overline{\sigma_Y}$ . Then  $s_0$  would be a non-generic value at which  $Q$  and some fence  $F$  in  $\mathcal{F}$  have a saddle intersection. Then 2.8 can be invoked. Such a saddle can't convert a meridian of  $X$  in  $F$  to a meridian of  $Y$  in  $F$ , so with no loss we can assume that  $\mathcal{B}_{s_0-\epsilon}$  is an  $X$ -set. Then by the saddle-box lemma,  $\mathcal{B}_{s_0+\epsilon}$  can't be a  $Y$ -set, so  $\mathcal{F}'_{s_0+\epsilon}$  must be a  $Y$ -set. Then by the saddle-parcel lemma,  $Q$  can be obtained from a surface  $Q'$ , for which  $\mathcal{B}_{s_0-\epsilon}$  is a disciplined boxing set, by doing 1-surgery along a spanning arc  $\gamma$  of an annulus component of  $F - Q'$ . (Again, monotonicity of  $Q'$  follows from 2.13).

Since no component of  $Q$  is closed, there's a path in  $Q' \cap \mathcal{B}$  from an end of  $\gamma$  to a point in  $\partial Q'$ . Slide the entire arc  $\gamma$  along, keeping it always a spanning arc of the subannulus on which its ends lie, until one of its ends lies on an arc component of  $Q' \cap \mathcal{F}'$ . At that point  $\gamma$  can be removed without producing a meridian disk in  $\mathcal{F}'$ . (The fact that  $\gamma$  can be kept a vertical spanning arc during this process strongly uses the fact that the closed components of  $Q' \cap \mathcal{F}'$  and  $Q' \cap \mathcal{F}$  are both monotonic.)  $\diamond$

#### 2.4. When no fencings are straight.

**Proposition 2.15.** *Suppose  $(Q, \partial Q) \subset (H, \partial_+ H)$  is a weakly incompressible splitting surface in a compression body  $H$ . Suppose, for a given cutting system  $\mathcal{C} \subset \partial_- H$ , there is no straight fencing system based on  $\mathcal{C}$ . Suppose, in addition, there is a disciplined fencing system  $\mathcal{F}$  based on  $\partial_- H$  and a secondary annulus  $\mathcal{A}$  in a boxing system extending which*

1.  $H - \mathcal{F}$  contains no meridian disk of either  $X$  or  $Y$ ,
2. all closed components of  $Q \cap \mathcal{A}$  are essential in  $\mathcal{A}$ , and
3. if there is a subannulus of  $\mathcal{F}$  parallel to a subannulus of  $Q - \mathcal{F}$ , then isotoping one across the other creates a meridian disk in a parcel.

Then each closed component of  $Q \cap \mathcal{A}$  is monotonic with respect to  $\Gamma \cap \mathcal{A}$ .

*Proof.* Let  $\Lambda$  be the 1-manifold  $Q \cap \mathcal{A}$ . As in 2.13, if  $\Lambda - \Gamma$  contains a subarc  $\lambda$  with its ends on the same component of  $\Gamma$ , then  $\lambda$  is parallel to a subarc of  $\Gamma$  via a “ $\partial$ -compressing disk” whose interior is disjoint from  $\Gamma$ . If the interior of the disk is disjoint from  $Q$  as well, we say  $\alpha$  is “outermost”. Suppose  $\lambda$  is an arc in  $\Lambda - \Gamma$  which has both ends on a component  $\gamma$  of  $\Gamma$ . Then the component of  $Q - \mathcal{F}$  in which  $\lambda$  lies is an annulus parallel to a subannulus of  $\mathcal{F}$ , for otherwise an outermost counterexample, when  $\partial$ -compressed to  $\mathcal{F}$ , would reveal a meridian disk in the complement of  $\mathcal{F}$ .

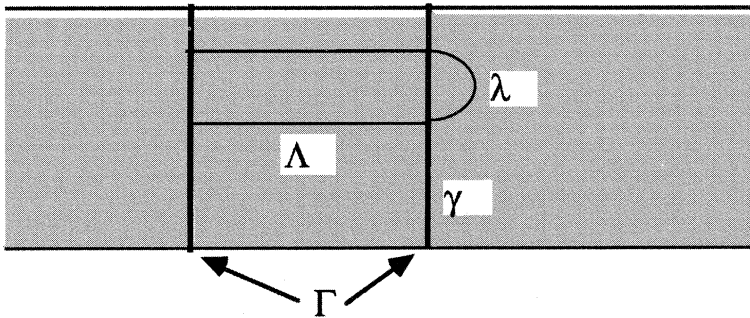

FIGURE 7

We have the following surprising consequence: If  $\lambda$  is an *outermost* arc then the subarcs of  $\Lambda - \Gamma$  adjacent to  $\lambda$  have only one end on  $\gamma$ . For if either has both ends on  $\gamma$ , then the annulus  $\alpha$  of  $Q - \mathcal{F}$  spanned by  $\lambda$  would be adjacent in  $Q$  to another annulus of  $Q - \mathcal{F}$ . Isotoping  $\alpha$  across  $\mathcal{F}$  could not then create a meridian in a parcel, contradicting our assumption 3. (See Figure 7.)

Now suppose not all closed components of  $\Lambda$  are monotonic, and let  $c$  be the non-monotonic one which is nearest to  $\partial_- H$  in  $\mathcal{A}$ . For concreteness, say the component of  $\mathcal{A} - \Lambda$  on the  $\partial_- H$  side of  $c$  lies in  $X$ . Consider an outermost arc  $\gamma$  of  $\Gamma - c$  lying on the  $\partial_+ H$  side of  $c$  in  $\mathcal{A}$ . Then in  $c$  there is a subarc  $\lambda_\gamma$  of  $c - \Gamma$  (perhaps not outermost in  $\Lambda - \Gamma$ ) which is parallel to  $\gamma$ . Again the subarcs of  $\Lambda - \Gamma$  adjacent to  $\lambda_\gamma$  have only one end on  $\gamma$ . For if either has both ends on  $\gamma$ , then the annulus of  $Q - \mathcal{F}$  spanned by  $\lambda_\gamma$  would be adjacent in  $Q$  to another annulus of  $Q - \mathcal{F}$  spanned by a subarc of  $c - \Gamma$  which is outermost in  $\Lambda - Q$ , since every component of  $\Lambda$  on the  $\partial_- H$  side of  $c$  is monotone. This would contradict the previous remark. (See Figure 8.)

So both segments of  $c - \Gamma$  adjacent to  $\lambda_\gamma$  each have an end on another component  $\gamma'$  of  $\Gamma$ . Consider the disk  $E$  bounded by  $\lambda_\gamma$  and a subsegment of  $\gamma$ . We suppose the interior of  $E$  is disjoint from  $\Lambda$  and derive a contradiction: The interior of  $E$  must then lie entirely in  $Y$ . If we push  $\lambda_\gamma$  across  $\gamma$  then we must, by assumption, create a meridian, and by construction this meridian must be in  $Y$ . Another way to create a meridian is to push an outermost arc of  $\Gamma$  on the  $\partial_- H$  side of  $c$  across a

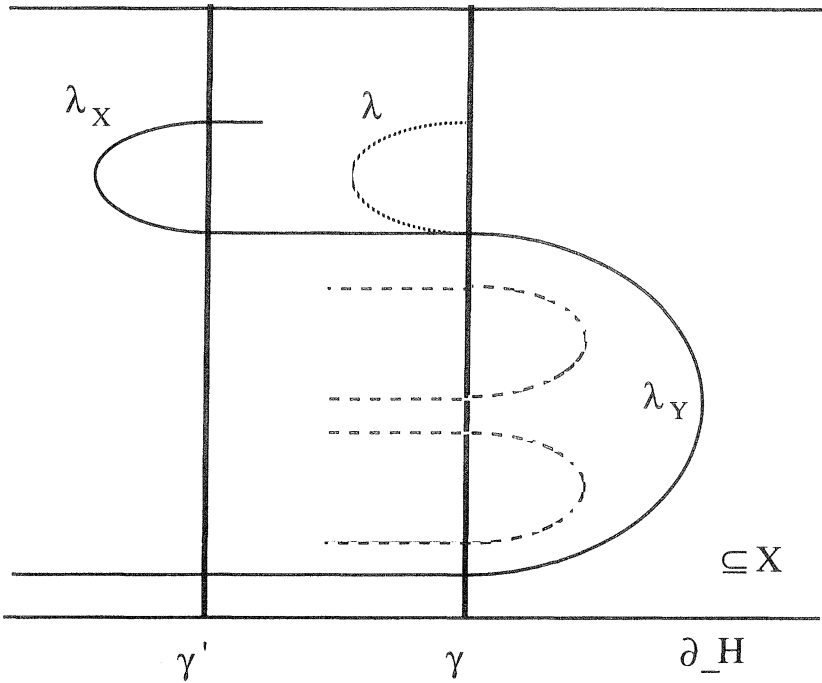

FIGURE 8

subarc  $\lambda_X$  of  $c$ , but this meridian is in  $X$ . If we do both simultaneously, we create meridians of both  $X$  and  $Y$  disjoint from  $\mathcal{F}$ , contradicting our assumption.

Finally, if the disk  $E$  contains other arcs of  $\Lambda$  then it's easy to see that for each such arc, the adjacent arcs in  $\Lambda - \Gamma$  must each have an end on  $\gamma'$ . Among all such arcs in  $E$  choose one (perhaps  $\lambda_Y$  itself) so that the disk it cuts off contains only outermost arcs. Then an argument much like Case 2 of 2.13 leads to a contradiction of weak incompressibility.  $\diamond$

**Proposition 2.16.** *Suppose  $(Q, \partial Q) \subset (H, \partial_+ H)$  is a weakly incompressible splitting surface, with no closed component, in a compression body  $H$ , and let  $\mathcal{C} \cup \mathcal{C}'$  be a special spine in  $\partial_- H$ . Suppose  $Q$  compresses both into  $X$  and into  $Y$ , but no disciplined fencing system based on  $\mathcal{C}$  is straight. Then there is a disciplined boxing system in  $H$  based on  $\mathcal{C} \cup \mathcal{C}'$ .*

*Proof.* The hypothesis guarantees the following special fact: If there is a meridian of  $X$ , say, in the complement of a disciplined fencing system  $\mathcal{F}$  based on  $\mathcal{C}$ , then there is no boxing system for which a secondary annulus contains a meridian of  $Y$ . Here's the argument: Suppose  $y$  is such a meridian curve in a secondary annulus  $\mathcal{A}$ . Isotope  $\mathcal{F}$  to eliminate all subannuli parallel to subannuli of  $Q$ . This won't affect the meridian of  $X$ , which is already disjoint from  $\mathcal{F}$ , and just isotopes  $y$  around in  $\mathcal{A}$ . The hypothesis guarantees that afterwards  $y$  still intersects  $\Gamma$  (otherwise it would also be disjoint from  $\mathcal{F}$  and so  $\mathcal{F}$  would be straight). Now  $\partial$ -compress  $y$  to an outermost arc  $\gamma$  of  $\Gamma$  in the disk bounded by  $y$ . This converts the subannulus of  $\mathcal{F}$  spanned by  $\gamma$  into a meridian of  $Y$  which was disjoint from  $\mathcal{F}$  before the  $\partial$ -compression, also contradicting the hypothesis.

Since  $H$  contains meridian disks for both  $X$  and  $Y$ , there is a bandotopy, parameterized by  $0 \leq s \leq 1$ , from a fencing system containing a meridian disk of  $X$  in a fence to one containing a meridian disk of  $Y$ . Let  $\sigma_X$  (resp.  $\sigma_Y$ ) denote those values of  $s$  for which either  $\mathcal{F}_s$  contains a meridian curve of  $X$  (resp.  $Y$ ), or  $\mathcal{F}_s$  can be extended to a boxing system  $\mathcal{B}$  which is an  $X$ -set (resp.  $Y$ -set) or for which  $\mathcal{F}'$  contains a meridian curve of  $X$  (resp.  $Y$ ). Here, as in 2.14,  $\mathcal{F}'$  is the fencing system consisting of the disk components of  $\mathcal{F}_s$  and the secondary annuli of  $\mathcal{B}$ .

*Case 1.* There is a generic value  $s_0$  which is neither in  $\sigma_X$  nor in  $\sigma_Y$ . Then, as in 2.11,  $\mathcal{F}_{s_0}$  (denoted now simply  $\mathcal{F}$ ) extends to a boxing system  $\mathcal{B}$  based on  $\mathcal{C} \cup \mathcal{C}'$  for which the posts  $\Gamma$  satisfy 2.10.3. No primary or secondary annulus contains a meridian disk, by construction, so, as in 2.14, any inessential closed intersection curve in these annuli is disjoint from  $\Gamma$ . So these can all be eliminated by an isotopy of  $\mathcal{B}$  rel  $\Gamma$ . Then  $\mathcal{B}$  satisfies all the properties of a disciplined boxing system, except that essential closed curves in  $Q \cap \mathcal{F}'$  may not be monotonic.

To ensure that they are monotonic, make the following adjustment: For any secondary annulus  $\mathcal{A}$  let  $\Lambda$  denote the set of curves  $Q \cap \mathcal{A}$ . Because  $s_0$  is neither in  $\sigma_X$  nor in  $\sigma_Y$ , there is no meridian of either  $X$  or  $Y$  disjoint from  $\mathcal{F}$ . This means that any arc in  $\Lambda - \Gamma$  which has both ends on the same component of  $\Gamma$  spans an annulus component of  $Q - \mathcal{F}$  (see 2.15). Push as many such annuli across  $\mathcal{F}$  as possible without creating a meridian of  $X$  or  $Y$  in  $H - \mathcal{F}$ . These moves can't create any closed component in  $\Lambda$ , and afterwards 2.15 guarantees that  $\Lambda \cap \mathcal{A}$  is monotonic. Repeat for every secondary annulus.

*Case 2.* There is a generic value  $s_0$  contained in both  $\sigma_X$  and  $\sigma_Y$ . Then with no loss we can assume, from the hypothesis of no straight fences, that there is no meridian curve of  $Y$  disjoint from  $\mathcal{F}_{s_0}$  (which we henceforth denote simply  $\mathcal{F}$ ). We can also assume there is no meridian curve of  $X$  or  $Y$  in a primary annulus, since such a meridian (of  $X$ , say) would be disjoint from the posts, by construction, and so disjoint from the meridian curve of  $Y$  guaranteed by  $s_0 \in \sigma_Y$ . Then we can remove all inessential intersection curves in  $\mathcal{F}$  by an isotopy of  $\mathcal{F}$  rel  $\Gamma$ , making  $\mathcal{F}$  disciplined. Furthermore, it's easy to see that  $\partial$ -compressing away the inessential arcs in  $\mathcal{F}$  has no relevant effect on the situation and, after these  $\partial$ -compressions, there is a unique choice of posts  $\Gamma$  in  $\mathcal{F}$ . Now consider a bandotopy from one collection of secondary annuli to another, with  $\Gamma$  fixed, so that at the beginning  $\mathcal{F}'$  contains a meridian of  $Y$  and at the end either there's a meridian of  $X$  in the secondary annuli or there's one in the complement of  $\mathcal{B}$ . The latter can't happen, by our initial remark, so during the bandotopy the meridian of  $Y$  in the secondary annulus changes to a meridian of  $X$ . The meridians can't exist simultaneously, nor can there be a saddle singularity switching one to the other, by strong irreducibility. So there's a generic point at which neither occurs. This establishes all but monotonicity, and furthermore (from the initial remark) establishes that there is no meridian of  $X$  or  $Y$  disjoint from  $\mathcal{F}$ . Now apply 2.15 as in case 1.

*Case 3.* There is an isolated point  $s_0$  of  $\overline{\sigma_X} \cap \overline{\sigma_Y}$ . Then the topology of  $Q - \mathcal{F}_{s_0}$  must change at  $s_0$ , so there is a saddle or half-saddle intersection of  $Q$  with  $\mathcal{F}_{s_0}$ . The half-saddle case is similar but easier than subcases 3a and 3b below, so we consider just the saddle case. There are three subcases to consider. (See Figure 9.)

*Subcase 3a.* The saddle singularity connects two arc components of  $Q \cap \mathcal{F}$ . Then a set of posts  $\Gamma$  may be chosen to be disjoint from the saddle tangency. If there

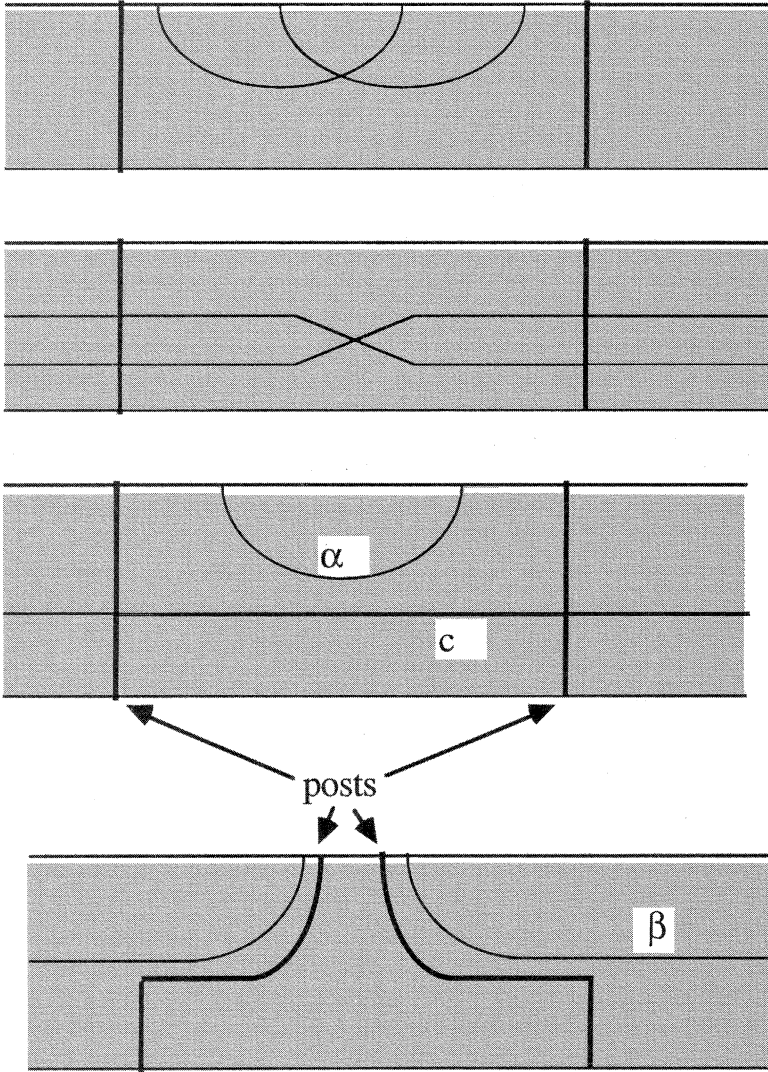

FIGURE 9

is any secondary annulus containing a meridian, then there is one making use of only these posts. Passing through the saddle point would have no effect on these meridians. So, since  $s_0$  is isolated, we can assume that there are no meridian curves in the secondary annuli at  $s_0 \pm \epsilon$ . But this means there's a boxing system  $\mathcal{B}$  at  $s_0 - \epsilon$  which is an  $X$ -set, say, and some other boxing system at  $s_0 + \epsilon$  which is a  $Y$ -set. Blend the two: Push the saddle point to the side it's on at  $s_0 + \epsilon$  and consider  $\mathcal{B}$ . The saddle-box lemma 2.8 then guarantees that  $\mathcal{B}$  is neither an  $X$ - nor a  $Y$ -set.

The most direct way to engineer monotonicity is to observe that at the singular moment  $s_0$  there is no meridian disk disjoint from  $\mathcal{F}$ , so we can apply the process of 2.15. The technical objection that  $\mathcal{F}$  and  $Q$  are not at that moment transverse can be overcome by a technical trick: Let  $\alpha$  be a proper arc in  $\mathcal{F} - Q$ , with ends



on  $\partial_+\mathcal{F}$ , so that  $\alpha$  intersects no closed curve in  $Q \cap \mathcal{F}$  but  $\alpha$  cuts off a disk  $E$  from  $\mathcal{F}$  that contains the saddle singularity point. (For example, choose an outermost (in  $\mathcal{F}$ ) arc of a regular neighborhood of the singular component of  $\mathcal{F} \cap Q$  at  $s_0$ .) Remove from  $H$  a neighborhood of  $E$  and the part of  $Q$  within it. The result is a setting in which 2.15 applies, and after completing the process described in that argument,  $H$  and  $Q$  can be restored.

*Subcase 3b.* The saddle singularity connects two essential curves of  $Q \cap \mathcal{F}$ . There are two possibilities: If the two curves are not parallel in  $Q$  then the singularity creates a meridian curve of  $X$ , say, in  $\mathcal{F}$ . But this meridian was previously disjoint from the fencing system, so a boxing system could have been chosen to contain it in a secondary annulus. This contradicts the assumption that  $s_0$  is isolated. If the two curves are parallel in  $Q$ , then passing through the saddle point is equivalent to passing the annulus in  $Q$  across the annulus in  $\mathcal{F}$  they bound. But any meridian of  $Q$  which existed before the subannuli are pushed across each other will persist afterwards, and again  $s_0$  would not be isolated.

*Subcase 3c.* At  $s_0$  the saddle singularity connects an essential curve  $c$  in  $Q \cap \mathcal{F}$  to an arc component  $\alpha$  of  $Q \cap \mathcal{F}$  (or, dually, an arc to itself by a band outside the disk in  $\mathcal{F}$  it cuts off). So at  $s_0 - \epsilon \in \sigma_X$  say both  $c$  and  $\alpha$  lie in  $\mathcal{F}$ , and at  $s_0 + \epsilon \in \sigma_Y$  they have been banded together to give a different arc component  $\beta$  of  $Q \cap \mathcal{F}$ . A meridian in a secondary annulus at  $s_0 + \epsilon$  would have existed at  $s_0 - \epsilon$ , so there can be no such meridian. This means that at  $s_0 + \epsilon$  there is a boxing system which is a  $Y$ -set; hence there is a meridian of  $Y$  disjoint from  $\mathcal{F}$ . Then even at  $s_0 - \epsilon$  there can be no meridian in a secondary annulus, by our first observation. But this means there's a boxing system  $\mathcal{B}$  at  $s_0 - \epsilon$  which is an  $X$ -set, say, and a boxing system at  $s_0 + \epsilon$  which is a  $Y$ -set, and the proof concludes much as in Subcase 3a. There are only two alterations: The posts for  $\mathcal{B}$  intersect the arc  $\beta$  and have to be pushed off  $\beta$  in  $\mathcal{F}$ . The effect on the intersection of  $Q$  with a secondary annulus  $\mathcal{A}$  is to band a component of  $Q \cap \mathcal{A}$  to  $\partial_+\mathcal{A}$  along a segment of a post, a move which cannot create a closed component. Also, instead of a disk, use for  $E$  the subannulus of  $\mathcal{F}$  cut off by  $\alpha$ . ◊

**Corollary 2.17.** *Suppose  $(Q, \partial Q) \subset (H, \partial_+H)$  is a weakly incompressible splitting surface, with no closed component, in a compression body  $H$ , and suppose  $\mathcal{C} \cup \mathcal{C}'$  is a special spine in  $\partial_-H$ . Suppose  $Q$  compresses both into  $X$  and into  $Y$ . Then there is a disciplined boxing system in  $H$  based on  $\mathcal{C} \cup \mathcal{C}'$ .*

*Proof.* If  $\mathcal{C}$  is the base of a disciplined straight fencing system for  $H$ , then apply 2.14. Otherwise apply 2.16. ◊

### 3. DISCIPLINED BOXING SYSTEMS IN STRONGLY IRREDUCIBLE HEEGAARD SPLITTINGS

The goal of this section is to prove

**Theorem 3.1.** *Suppose  $A \cup_P B$  and  $X \cup_Q Y$  are strongly irreducible Heegaard splittings of the same manifold  $M$ , with  $\partial_-A = \partial_-X = \partial_0M$  and  $\partial_-B = \partial_-Y = \partial_1M$ . Suppose  $\mathcal{C}_0, \mathcal{C}'_0$  and  $\mathcal{C}_1, \mathcal{C}'_1$  are special spines for  $\partial_0M$  and  $\partial_1M$  respectively. Then one of  $P$  or  $Q$ , say  $Q$ , may be isotoped so that  $P \cap Q$  is a nonempty collection of curves which are essential in both  $P$  and  $Q$ , so that there are boxing systems  $\mathcal{B}_A$  in  $A$  and  $\mathcal{B}_B$  in  $B$  which are disciplined with respect to  $A \cap Q$  and  $B \cap Q$  respectively, and so that at least one of  $X$  or  $Y$  contains no meridian disks for  $P$ .*

We begin with the following construction, produced much as in [RS1, 6.5].

For  $F : M \times I \rightarrow M$  an isotopy of  $M$ , let  $f_t : M \rightarrow M$  denote  $F|M \times \{t\}$ , and let  $Q_t$  (resp.  $X_t, Y_t$ ) denote  $f_t(Q)$  (resp.  $f_t(X), f_t(Y)$ ).

**Proposition 3.2.** *For one of the pairs of letters  $A, B$  or  $X, Y$  (say the latter), there is an isotopy  $F : M \times I \rightarrow M$  so that*

1.  $F|Q$  is generic and compression-free with respect to  $P$ ,
2. there is a meridian disk of  $X_0$  which is disjoint from  $P$ ,
3. there is a meridian disk of  $Y_1$  which is disjoint from  $P$ ,
4. every component of  $P \cap Q_0$  and  $P \cap Q_1$  is essential, and
5. for any generic  $0 \leq t \leq 1$ , at least one of  $X_t$  or  $Y_t$  contains no near meridian disks for  $P$ .

*Proof.* The proof is a variant on the proof of [RS1, 6.5], to which we defer for most details. There are several steps:

*Step 1.* Construct a 2-parameter family of positionings of  $P$  and  $Q$  in  $M$ , determined by sweep-outs.

Let  $\Xi_A, \Xi_B, \Xi_X$  and  $\Xi_Y$  be disjoint spines of  $A, B, X$  and  $Y$  in  $M$  respectively. Then the region between  $\partial_0 M \cup \Xi_A$  and  $\partial_1 M \cup \Xi_B$  is homeomorphic to  $P \times (0, 1)$  and the region between  $\partial_0 M \cup \Xi_X$  and  $\partial_1 M \cup \Xi_Y$  is homeomorphic to  $Q \times (0, 1)$ . We can jiggle these parameterizations slightly so that they are transverse and so that for some small  $\epsilon$ ,

1.  $P \times \{\epsilon\}$  is transverse to  $Q \times \{\epsilon\}$  and any intersection curve is parallel to an essential curve in  $\partial_0 M$ ,
2.  $P \times \{\epsilon\}$  and  $Q \times \{\epsilon\}$  are disjoint from  $\Xi_B$  and  $\Xi_Y$  respectively,
3.  $P \times \{1 - \epsilon\}$  is transverse to  $Q \times \{1 - \epsilon\}$  and any intersection curve is parallel to an essential curve in  $\partial_1 M$ , and
4.  $P \times \{1 - \epsilon\}$  and  $Q \times \{1 - \epsilon\}$  are disjoint from  $\Xi_A$  and  $\Xi_X$  respectively.

Then reparameterize so that  $P_s, 0 \leq s \leq 1$ , runs from  $P \times \{\epsilon\}$  to  $P \times \{1 - \epsilon\}$  and  $Q_t, 0 \leq t \leq 1$ , runs from  $Q \times \{\epsilon\}$  to  $Q \times \{1 - \epsilon\}$ . Then as  $P$  sweeps from  $P_0$  to  $P_1$  it will intersect both  $\Xi_X$  and  $\Xi_Y$ , and thus there will be some value of  $s$  for which  $P_s - Q_0$  contains some meridian disks of  $X$  and some value for which  $P_s - Q_1$  contains some meridian disks for  $Y$ . Similarly there will be values of  $t$  for which  $Q_t - P_0$  and  $Q_t - P_1$  contain meridian disks of  $A$  and  $B$  respectively.

Just as in [RS1, 3], the interior of the square  $I \times I = \{(s, t) | 0 \leq s, t \leq 1\}$  decomposes into four types of strata, the regions, the edges, the crossing vertices, and the birth-death vertices, depending on the nature of  $P_s \cap Q_t$ . And, as there, we will call the 1-complex  $\Gamma$  of edges and vertices the *graphic* in the interior of  $I \times I$ .

*Step 2.* Label the regions of the graphic.

Pick  $(s, t)$  in a given region of the graphic and, in this step, let  $P$  denote  $P_s$  and  $Q$  denote  $Q_t$ . Label the region according to the following scheme:

1. If *both*  $X$  and  $Y$  contain near meridian disks of  $A$  (resp.  $B$ ), choose the label  $A$  (resp.  $B$ ).
2. If *both*  $A$  and  $B$  contain near meridian disks of  $X$  (resp.  $Y$ ), choose the label  $X$  (resp.  $Y$ ).

Observe the following: If the region is unlabelled then  $P \cap Q$  is compression-free, for if there were a component which is essential in  $P$  but inessential in  $Q$ , say, then consider an innermost such component  $c$  in  $Q$ . Then in  $Q$ ,  $c$  bounds a near meridian

disk  $D$  for either  $A$  or  $B$ , depending on whether a neighborhood of  $c$  in  $D$  lies in  $A$  or  $B$ . If for  $A$ , for example, push-offs of  $D$  would then give near meridian disks for  $A$  in both  $X$  and  $Y$ .

The upshot is that the labelling defined here is similar to the labelling by  $A, B, X, Y$  in [RS1, 4], except here some additional regions may be labelled. But, just as in [RS1, 5.1], no two adjacent regions have labels  $A$  and  $B$  or labels  $X$  and  $Y$ . For a saddle tangency in which the saddle point in  $P$  passes, say, from  $X$  to  $Y$  cannot destroy a near meridian disk in  $Y$  or create a near meridian disk in  $X$ . So if a label  $A$  occurred beforehand and a label  $B$  afterwards, there would, in either position, be a meridian curve of  $A$  in  $Y$  and a meridian curve of  $B$  in  $X$ , a contradiction.

We continue as in [RS1, 5]: Label a region  $a$  if all curves of  $P \cap Q$  are inessential in both surfaces and a spine of  $Q$  lies in  $A$ . Similarly for labels  $b, x, y$ . Then, by a slightly altered argument, [RS1, 5.3] remains true and the argument proceeds. The goal is not to verify that there is an unlabelled region ([RS1, 5.9]), for by construction there are typically no labels near the corners  $[0, 0]$  and  $[1, 1]$ . Rather the goal is [RS1, 5.10], which describes a path through the unlabelled region from a region labelled  $X$  to a region labelled  $Y$ . As in [RS1, 6.5], this gives an isotopy satisfying all the conditions except perhaps the last.

To verify that the last is also satisfied, it suffices to show that in an unlabelled region at least one of  $X$  or  $Y$  contains no near meridian disks of either  $A$  or  $B$ . But suppose both contained such near meridian disks. If one contained a meridian curve of  $A$  and the other a meridian curve of  $B$ , it would violate strong irreducibility. If both contained near meridian disks of  $A$ , say, this would mean that the the region should have been labelled  $A$ . ◊

For the isotopy of 3.2, let  $\tau_X \subset [0, 1]$  (resp.  $\tau_Y$ ) denote the set of  $t \in [0, 1]$  so that  $Q_t$  is transverse to  $P$  and there is a near meridian disk of  $X_t$  (resp.  $Y_t$ ) disjoint from  $P$ . Then  $0 \in \tau_X$  and  $1 \in \tau_Y$ .

**Proposition 3.3.** *Suppose there is a generic value  $t_0$  that is in neither  $\tau_X$  nor  $\tau_Y$ . Then  $Q$  may be isotoped so that it is transverse to  $P$ ,  $P \cap Q$  is non-empty, each component of  $P \cap Q$  is essential in both surfaces, and the surface  $Q \cap A$  (resp.  $Q \cap B$ ) is incompressible in  $A$  (resp.  $B$ ).*

*Proof.* First note that there is no essential curve in  $Q_{t_0}$  that bounds a disk disjoint from  $P$ . For if there were, then an innermost disk argument shows there's such a curve  $c$  and a disk  $D$  it bounds which intersects  $Q_{t_0}$  only in inessential curves. Then  $c$  is a meridian of either  $X_{t_0}$  or  $Y_{t_0}$ .

The property that there is no essential curve in  $Q_{t_0}$  that bounds a disk disjoint from  $P$  is unaffected by isotoping  $Q$  to remove all curves in  $P \cap Q$  which are inessential (in both surfaces). Once this is done each component of  $P \cap Q$  is essential in both surfaces. Moreover, the surface  $Q \cap A$  (resp.  $Q \cap B$ ) is incompressible in  $A$  (resp.  $B$ ). For if the boundary of any compressing disk for  $Q \cap A$  were inessential in  $Q$  then the disk in  $Q$  it bounds would have to intersect  $P$ , giving an inessential curve in  $P \cap Q$ . ◊

*Proof of 3.1.* In each case below, the requirement that at least one of  $X$  or  $Y$  contains no meridian disks for  $P$  will be guaranteed by the last condition of 3.2.

*Case 1.* There is a generic value  $t_0$  that is in neither  $\tau_X$  nor  $\tau_Y$ .

In this case just apply 3.3 and 2.11.

*Case 2.* There is a generic value  $t_0$  that is in  $\tau_X \cap \tau_Y$ .

In this case there are essential curves  $x$  and  $y$  which, in  $Q_{t_0} - P$ , bound near meridian disks in  $X_{t_0}$  and  $Y_{t_0}$  respectively. It follows from strong irreducibility of  $Q$  that these essential curves must both be on the same side of  $P$ , say in  $A$ . The parameter  $t$  isn't changed in the rest of the argument, so we'll revert to  $Q$  as notation for  $Q_{t_0}$ . We may as well eliminate by an isotopy any inessential curves of  $P \cap Q$  and observe that then  $Q \cap B$  is incompressible in  $B$ . In particular, 2.11 demonstrates that  $\mathcal{C}_1 \cup \mathcal{C}'_1$  extends to a disciplined boxing system for  $Q \cap B$ . Similarly 2.17 demonstrates that  $\mathcal{C}_0 \cup \mathcal{C}'_0$  extends to a disciplined boxing system for  $Q \cap A$ .

*Case 3.* There is an isolated point  $t_0$  of  $\overline{\tau_X} \cap \overline{\tau_Y}$ .

Since  $t_0$  is isolated, it's neither generic nor at a center tangency. So there is a saddle tangency of  $Q_{t_0}$  with  $P$ . With no loss assume that as  $t$  passes from  $t_0 - \epsilon$  to  $t_0 + \epsilon$ , the saddle point in  $Q$  passes from  $A$ , say, to  $B$  and that  $t_0 - \epsilon$  is in  $\tau_X$  and  $t_0 + \epsilon$  is in  $\tau_Y$ .

By definition, there is a curve  $x$  bounding a near meridian disk  $D$  of  $X$  in  $Q_{t_0 - \epsilon} - P$ . If  $x$  lay in  $B$  then, since the saddle point passes from  $A$  to  $B$ ,  $D$  would persist to  $t_0 + \epsilon$ . But then  $t_0 + \epsilon$  would also be in  $\tau_X$ . So we need only consider the case in which  $x \subset A$ . Symmetrically, at  $t_0 + \epsilon$  there is a near meridian disk for  $Y$  in  $B$ . Furthermore  $Q_{t_0 + \epsilon} \cap A$  can contain no near meridian disks, for if it contained a meridian curve for  $X$ , the curve and  $y$  would contradict strong irreducibility, and if it contained a near meridian disk of  $Y$  then it would persist to  $Q_{t_0 - \epsilon} \cap A$  and contradict the isolation of  $t_0$ . Similarly  $Q_{t_0 - \epsilon} \cap B$  can contain no near meridian disks. Since passing the saddle point through  $P$  in either direction destroys a meridian curve, none of the three curves of  $Q_{t_0 \pm \epsilon}$  incident to the saddle point is inessential in either  $P$  or  $Q$ . After removing by an isotopy all non-singular inessential curves of  $P \cap Q_{t_0 \pm \epsilon}$ , we have that  $Q_{t_0 + \epsilon} \cap A$  is incompressible in  $A$  and  $Q_{t_0 - \epsilon} \cap B$  is incompressible in  $B$ .

Now apply 2.11 to both  $A$  and  $B$  to get boxing systems  $\mathcal{B}_A$  and  $\mathcal{B}_B$  for  $A$  and  $B$  respectively which are disciplined for  $Q_{t_0 + \epsilon} \cap A$  and  $Q_{t_0 - \epsilon} \cap B$  respectively. Now passing between  $Q_{t_0 \pm \epsilon}$  is equivalent to passing a band back and forth. Although it doesn't quite follow from general position that we can take this band to lie in a single box, we can assume that the band in  $P$  never runs into the base of a post of either  $\mathcal{B}_A$  or  $\mathcal{B}_B$ . So the only effect on  $Q \cap \mathcal{B}_A$  in  $\mathcal{B}_A$  (or  $Q \cap \mathcal{B}_B$  in  $\mathcal{B}_B$ ) is to add or remove some arcs of intersection disjoint from the posts. The only way this can affect whether  $\mathcal{B}_A$  or  $\mathcal{B}_B$  is disciplined is if it affects the requirement that  $Q \cap (A - \mathcal{B}_A)$  (or  $Q \cap (B - \mathcal{B}_B)$ ) consists of disks. That is,  $\mathcal{B}_A$  (resp.  $\mathcal{B}_B$ ) might be an  $X$ - (resp.  $Y$ -) set for  $Q_{t_0 - \epsilon} \cap A$  (resp.  $Q_{t_0 + \epsilon} \cap B$ ). But not both can happen, essentially by the saddle-box lemma 2.8. So, say,  $\mathcal{B}_A$  is not an  $X$ -set for  $Q_{t_0 - \epsilon} \cap A$ , so both  $\mathcal{B}_A$  and  $\mathcal{B}_B$  are disciplined boxing sets for  $Q_{t_0 - \epsilon} \cap A$  and  $Q_{t_0 - \epsilon} \cap B$ .  $\diamond$

#### 4. SPINES AND STABILIZATION

**Lemma 4.1.** *Suppose  $(Q, \partial Q) \subset (H, \partial_+ H)$  is a properly imbedded surface in a compression body  $H$  and suppose some spine of  $Q$  has the property that the complement of its regular neighborhood in  $H$  is also a compression body. Then the complement in  $H$  of a regular neighborhood of any spine of  $Q$  is a compression body.*

*Proof.* One can move between two spines of  $Q$  by a sequence of operations consisting of adding or removing edges inside complementary disks and of edge slides. The last has no effect on the complement of the spine in  $H$ . The effect of the former two is to stabilize or destabilize the splitting, and so the complement in  $H$  remains a compression body.  $\diamond$

**Proposition 4.2.** *Suppose  $(Q, \partial Q) \subset (H, \partial_+ H)$  is a properly imbedded incompressible splitting surface, with no closed component, in a compression body  $H$ . Then for any spine  $\Lambda$  of  $Q$ ,  $H - \eta(\Lambda)$  is also a compression body.*

*Proof.* By 4.1 it suffices to show this for some spine of  $Q$ .

We may as well assume  $Q$  is connected. The proof is by induction on  $-\chi(Q)$ . If  $Q$  is not  $\partial$ -compressible, then, since  $Q$  contains no closed component,  $Q$  is a disk and there's nothing to prove. So suppose  $Q$  is  $\partial$ -compressible and let  $\beta$  be a proper arc in  $Q$  which  $\partial$ -compresses to  $\partial_+ H$ . Let  $Q'$  be the surface obtained by the  $\partial$ -compression and let  $\Lambda'$  be a spine for  $Q'$ . By induction,  $H - \eta(\Lambda')$  is a compression body.  $H - \eta(\Lambda)$  is obtained by removing the neighborhood of the arc  $\beta$  which is parallel to an arc in  $\partial_+(H - \eta(\Lambda'))$ .  $\diamond$

**Lemma 4.3.** *Suppose  $(Q, \partial Q) \subset (H, \partial_+ H)$  is a properly imbedded surface, with no closed component, in a compression body  $H$  and  $\mathcal{B}$  is a disciplined boxing system for  $H$  with respect to  $Q$ . Let  $\Lambda$  be the proper 1-complex  $Q \cap \mathcal{B} \subset H$ . Then  $H - \eta(\Lambda)$  is also a compression body.*

*Proof.* Let  $\Gamma$  be the set of posts of the boxing system  $\mathcal{B}$ . The strategy is to slide edges of  $\Lambda$  over  $\partial_+ H$  and other edges, and cancel edges of  $\Lambda$  against compressing disks, until  $\Lambda$  consists entirely of subarcs of  $\Gamma$ , each with one end on  $\partial_+ H$ . All operations will leave the 0-skeleton  $\Lambda_0 = \Lambda \cap \Gamma$  unchanged.

Before launching this strategy, let us simplify the picture somewhat. Notice that, for  $\mathcal{F}$  the fencing system in  $\mathcal{B}$ , nothing is lost by doing  $\partial$ -compressions to  $Q$  along the arc components of  $Q \cap \mathcal{F}$ . Indeed, such moves can be regarded as destabilizations of  $\Lambda$  and what is left of  $\Lambda$  is still a spine of the resulting surface  $Q'$  since every component of  $Q' - \mathcal{B}$  remains a disk. So we can assume that  $Q$  is disjoint from any disk component of  $\mathcal{F}$  and intersects each annulus component of  $\mathcal{F}$  only in (essential) simple closed curves.

The proof then proceeds by induction on the number of edges of  $\Lambda$  outside of  $\Gamma$  (see Figure 10). Suppose for some primary or secondary annulus  $\mathcal{A}$  of  $\mathcal{B}$  there is a disk component in  $\mathcal{A} - \Lambda$ , and let  $D$  be an innermost one. First suppose that the interior of  $D$  is disjoint from  $\Gamma$ . Since no component of  $Q \cap \mathcal{A}$  was an inessential curve in  $\mathcal{A}$ ,  $D$  can't lie entirely in  $Q \cap \mathcal{A}$ . This means that part of  $\partial D$  lies on  $\partial_+ \mathcal{A} \cup \Gamma$ . But  $\partial_+ \mathcal{A} \cup \Gamma$  deformation retracts to  $\partial_+ \mathcal{A}$ , so  $\partial D$  can't lie entirely in this complex either. Hence there's at least one edge  $\lambda$  in  $\partial D$  which lies in  $\Lambda - (\partial_+ \mathcal{A} \cup \Gamma)$ . Then  $D$  cancels  $\lambda$ , completing the induction.

If the interior  $D$  is not disjoint from  $\Gamma$ , then an outermost arc  $\alpha$  of  $\Gamma$  in  $D$  cuts off a disk  $D'$  bounded by  $\alpha$  and an arc  $\beta$  in  $\Lambda \cup \partial_+ H$ . Just as before, there must be an edge  $\lambda \in \beta$  which doesn't lie in  $\partial_+ H \cup \Gamma$ . Then  $D'$  can be used to slide  $\lambda$  to  $\alpha$ , completing the inductive step.

Suppose then that in each primary or secondary annulus of  $\mathcal{B}$  the complementary components of  $\Lambda$  are all annuli. Notice that sliding and cancelling edges does not alter the fact (from the definition of  $\Lambda$ ) that  $\partial_+ H \cup \Lambda$  is connected. Unless all of  $\Lambda$  lies in  $\Gamma$  (in which case we are done) there is a path in  $\Lambda$  from any edge not

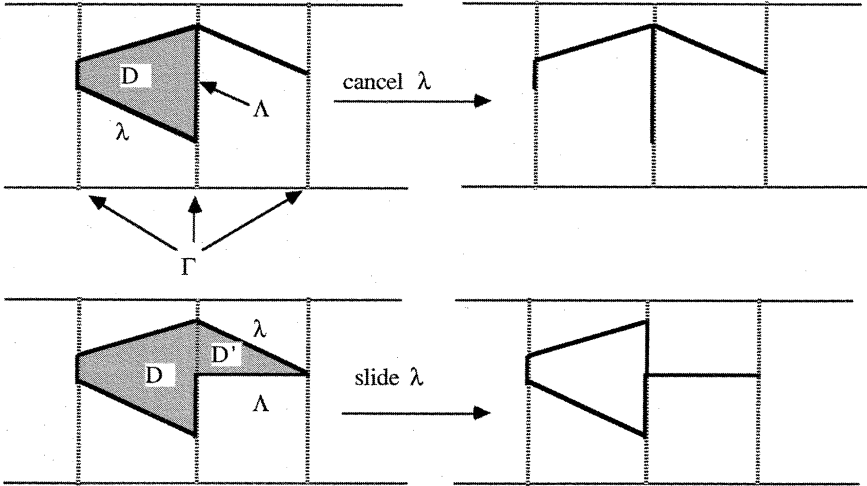

FIGURE 10

in  $\Gamma$  to  $\partial_+H$ . Choose a shortest such path, from an edge  $\lambda$  say, and let  $\mathcal{A}$  be the primary or secondary annulus that contains  $\lambda$  (and so contains the entire path). Let  $\Lambda_{\mathcal{A}}$  be the component of  $(\Lambda \cup \partial_+H) \cap \mathcal{A}$  containing  $\lambda$ , hence also  $\partial_+\mathcal{A}$ . Since no component of  $\mathcal{A} - \Lambda$  is a disk,  $\Lambda_{\mathcal{A}}$  is the union of  $\partial_+\mathcal{A}$  and some trees in  $\Lambda$  each with exactly one end in  $\partial_+\mathcal{A} \in \partial_+H$ . Every vertex of  $\Lambda_{\mathcal{A}}$  lies on  $\Lambda_0$ , hence in  $\Gamma$ . Since  $\Lambda_{\mathcal{A}}$  contains  $\lambda$  and so is not contained in  $\Gamma$ , there is a path in  $\Gamma - \Lambda_{\mathcal{A}}$  from a vertex of  $\Lambda_{\mathcal{A}}$  to  $\partial_+\mathcal{A}$ . It follows from monotonicity of the closed components of  $Q \cap \mathcal{A}$  that the shortest such arc has interior disjoint from  $\Lambda$  and so cuts off a disk, the rest of whose boundary lies in  $\Lambda_{\mathcal{A}}$ . An outermost arc argument on pieces of  $\Gamma$  lying in this disk gives such an arc  $\alpha$  for which the cut-off disk has interior disjoint from  $\Gamma$ . Now the previous argument locates an edge  $\lambda'$  of  $\Lambda - \Gamma$  in the boundary of the disk which can be slid to  $\alpha$ , completing the induction. (See Figure 11.)  $\diamond$

**Corollary 4.4.** *Suppose  $(Q, \partial Q) \subset (H, \partial_+H)$  is a properly imbedded weakly incompressible splitting surface, with no closed component, and suppose  $Q$  compresses both into  $X$  and into  $Y$ . Then for any spine  $\Lambda$  of  $Q$ ,  $H - \eta(\Lambda)$  is a compression body.*

*Proof.* By 2.17 there is a disciplined boxing system for  $Q$  in  $H$ . The result then follows from 4.3 and 4.1.  $\diamond$

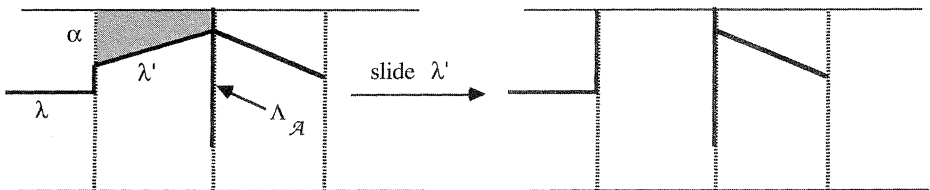

FIGURE 11

5. DESTABILIZING ANNULAR 1-HANDLES

Suppose  $H$  is a compression body and  $(\mathcal{A}, \partial\mathcal{A}) \subset (H, \partial_+H)$  is a finite set of  $\partial$ -compressible properly imbedded annuli all of whose boundary curves are essential in  $\partial_+H$ . Suppose  $\gamma$  is a set of spanning arcs for  $\mathcal{A}$  and  $\tau$  is a regular neighborhood of  $\gamma$  in  $H$ . We view  $\tau$  as a collection of 1-handles added to  $P = \partial_+H$ , each corresponding to an annulus in  $\mathcal{A}$ . Let  $H'$  denote the closure of  $H - \eta(\tau)$ . Since a spanning arc of a  $\partial$ -compressible annulus in  $H$  is parallel to an arc on  $\partial H$ , it's apparent that  $H'$  is also a compression body. Let  $P'$  denote  $\partial H'$ .

**Proposition 5.1.** *There is an ordering  $A_1, A_2, \dots, A_n$  of  $\mathcal{A}$  and, for each of all but at most  $-\chi(\partial_+H) + \chi(\partial_-H) - |\partial_-H|$  of the  $A_i$  there is a properly imbedded disk  $E_i$  in  $H'$  so that the  $E_i$  are all disjoint and have the following properties:*

1.  $\partial E_i$  is disjoint from the 1-handles corresponding to the annuli  $A_k, k > i$ .
2.  $\partial E_i$  runs exactly once across the 1-handle corresponding to  $A_i$ .
3.  $\partial E_i$  is disjoint from any component of  $P - \partial\mathcal{A}$  which is not an annulus.

*Proof.* The proof is a minor variation of the rather elaborate argument of [RS1, 9.1], and we refer to that paper for the key idea and the notation  $n_-v$ . Each complementary component  $V$  of  $\mathcal{A}$  in  $H$  is a compression body with  $\partial_-V = (\partial_-V \cap \partial_-H)$ . The argument of [RS1, 9.1] shows that always  $\chi(V) - \chi(\partial_-V) + |\partial_-V| \leq 1 - n_-(v)$  and that the set  $\Upsilon$  of components  $V$  which are not solid tori with  $n_-(v) = 1$  has no more than  $-\chi(H) + \chi(\partial_-H)$  elements. Summing over  $\Upsilon$ , we get

$$\sum_{V \in \Upsilon} (1 - n_-(v)) \geq \chi(H) - \chi(\partial_-H) + |\partial_-H|.$$

As in [RS1, 9.1] we are interested in  $e = \sum_{V \in \Upsilon} (n_-(v))$ , which here satisfies

$$|\Upsilon| - e \geq \chi(H) - \chi(\partial_-H) + |\partial_-H|$$

or

$$\begin{aligned} e &\leq |\Upsilon| - (\chi(H) - \chi(\partial_-H) + |\partial_-H|) \\ &\leq -2\chi(H) + 2\chi(\partial_-H) - |\partial_-H| = -\chi(\partial_+H) + \chi(\partial_-H) - |\partial_-H| \end{aligned}$$

◊

6. FINDING SPINAL SPLITTING SURFACES

If  $\mathcal{F}_A$  and  $\mathcal{F}_B$  are fencing systems for  $A$  and  $B$  respectively and the curve systems  $\mathcal{F}_A \cap P$  and  $\mathcal{F}_B \cap Q$  are in general position in  $P$ , then  $\mathcal{F} = \mathcal{F}_A \cup \mathcal{F}_B$  is called a fencing system for  $A \cup_P B$ . We denote  $\mathcal{F} \cup P$  by  $K_{\mathcal{F}}$ . Similarly if  $\mathcal{B}_A$  and  $\mathcal{B}_B$  are boxing systems for  $A$  and  $B$  respectively, and the complexes  $\mathcal{B}_A \cap P$  and  $\mathcal{B}_B \cap Q$  are in general position in  $P$ , then  $\mathcal{B} = \mathcal{B}_A \cup \mathcal{B}_B$  is called a boxing system for  $A \cup_P B$ . We denote  $\mathcal{B} \cup P$  by  $L_{\mathcal{B}}$ .

**Definition 6.1.** Suppose  $\Delta_A$  and  $\Delta_B$  are (not necessarily complete) collections of meridian disks for  $A$  and  $B$  respectively, and  $K$  is the 2-complex  $P \cup \Delta_A \cup \Delta_B$ . Then  $K$  has spinal intersection with  $Q$  if  $K \cap Q$  contains a spine of  $Q$  and, for each disk  $D \in (\Delta_A \cup \Delta_B)$ ,  $D \cap Q$  is a single arc. We say that  $P$  is spinal with respect to  $Q$  if there is some collection of meridian disks whose union with  $P$  has spinal intersection with  $Q$ .

**Theorem 6.2.** *Let  $P$  and  $Q$  be Heegaard splitting surfaces in  $M$  of genus  $p \geq 2$  and  $q \geq 2$  respectively, so that  $P \cap Q$  is a nonempty collection of curves which are essential in both surfaces. Suppose there is a disciplined boxing system  $\mathcal{B}$  for  $A \cup_P B$ . Then after at most  $7q + 4p + \chi(\partial M) - |\partial M| - 11$  stabilizations of  $P$ ,  $P$  is spinal with respect to  $Q$ .*

*Proof.* Since  $\mathcal{B}$  is disciplined, the complex  $\kappa = L_{\mathcal{B}} \cap Q$  contains an entire spine of  $Q$ . It is the union of the closed curves  $P \cap Q$  and the graph  $\Lambda = Q \cap \mathcal{B}$ . Let  $A'$  be obtained from  $A$  by attaching a neighborhood of  $\Lambda \cap B$ , let  $B'$  be obtained from  $B$  by attaching a neighborhood of  $\Lambda \cap A$  and let  $P'$  be the surface  $A' \cap B'$ . It follows from [ST1, 2.12] and 4.2 that  $P'$  stabilizes  $P$ . It then follows from 4.1 that the same is true for any subgraph of  $\Lambda \cap A$  (resp.  $\Lambda \cap B$ ) that is a spine for  $Q \cap A$  (resp.  $Q \cap B$ ). Much as in [RS1, 10.2] (here improved slightly, since there there was possibly a single inessential curve of intersection), such a spine would consist of a spanning arc in each annulus of  $Q - P$ , and, in the union of the other components of  $Q - P$ , a certain subgraph whose edges outnumber its interior vertices by  $4q - 4$ .

Again as in [RS1, 10.2], among the curves of  $P \cap Q$  there are at most  $3q - 3$  distinct families of mutually parallel curves in  $Q$ , and so a total of  $7q - 7$  arcs which we will not destabilize. Now 5.1 gives a way of destabilizing the 1-handles coming from all but  $4p - 4 + \chi(\partial M) - |\partial M|$  of the remaining annuli. So the total number of stabilizations needed to make  $P$  spinal is  $7q + 4p + \chi(\partial M) - |\partial M| - 11$ , as required.  $\diamond$

## 7. SPINAL INTERSECTIONS AND STABILIZATION

**Definition 7.1.** Let  $S$  be a connected closed surface. A properly imbedded arc  $\alpha \subset S \times I$  is vertical if it is properly isotopic to  $\{point\} \times I$ .

Similarly, for  $H$  a compression body, a properly imbedded arc  $\alpha \subset H$  is vertical if there is a complete collection  $\Delta$  of defining 2-disks for  $H$  in the complement of  $\alpha$ , and  $\alpha$  is vertical in one of the product complementary components of  $\Delta$ .

*Remark.* By [F, Lemma 1.1] this is equivalent to saying that in the component of  $H - \eta(\Delta)$  in which  $\alpha$  lies, the complement of an open regular neighborhood of  $\alpha$  is a handlebody.

**Proposition 7.2.** *Suppose  $A \cup_P B$  and  $X \cup_Q Y$  are strongly irreducible Heegaard splittings of the same manifold  $M$ , with  $\partial_- A = \partial_- X = \partial_0 M \neq \emptyset$  and  $\partial_- B = \partial_- Y = \partial_1 M$ . Suppose  $P \cap Q$  is a nonempty collection of simple closed curves which are essential in both  $P$  and  $Q$ . Suppose further that for cutting systems  $\mathcal{C}, \mathcal{C}'$  in  $\partial_0 M$  there are disciplined boxing systems  $\mathcal{B}_A$  and  $\mathcal{B}_X$  for  $A$  and  $X$  with respect to  $Q$  and  $P$  respectively. Then for each component  $S$  in  $\partial_0 M$  there is a component  $\beta$  of  $P \cap Q$  and an arc  $\alpha$  in  $A \cap X$  so that one end of  $\alpha$  is on  $\beta$ , the other end is on  $S$  and  $\alpha$  is vertical in both  $A$  and  $X$ .*

*Proof.* *Case 1.* There are curves  $c \in \mathcal{C} \cap S$  and  $c' \in \mathcal{C}' \cap S$  which intersect in a single point and, for the annuli  $\mathcal{A}$  and  $\mathcal{A}'$  based on  $c$  and  $c'$  in  $\mathcal{B}_A$  and  $\mathcal{B}_X$  respectively, neither  $\mathcal{A} \cap Q$  nor  $\mathcal{A}' \cap P$  contains a simple closed curve.

Consider, in this case, the 1-manifold  $\mathcal{A} \cap \mathcal{A}'$ . It has a single boundary point on  $\partial_0 M$ , namely  $c \cap c'$ . Let  $\alpha$  be the component of  $\mathcal{A} \cap \mathcal{A}'$  that contains this point. Then the other end of  $\alpha$  must be on either  $\partial_+ \mathcal{A}$  or  $\partial_+ \mathcal{A}'$ , say the former. Then  $\alpha$  spans a spanning annulus of  $A$  and so is vertical in  $A$ . The end of  $\alpha$  in  $\partial_+ \mathcal{A}$  lies on an arc component of  $P \cap \mathcal{A}'$ . Adjoining part of this arc component to  $\alpha$  creates a



spanning arc  $\alpha'$  for  $\mathcal{A}'$  which is then vertical in  $X$ . But since  $\alpha'$  is the union of a vertical arc in  $A$  and a subarc of  $P$ , it's (properly isotopic in  $X$  to) a vertical arc in  $A$  as well.

*Case 2.* Every annulus in  $\mathcal{B}_A$  (resp. every annulus in  $\mathcal{B}_X$ ) based on  $S$  contains an essential curve of intersection with  $Q$  (resp.  $P$ ).

Then the collection of all the essential simple closed curves which are closest to  $S$  forms a spine of  $S$  in  $P$ . Since  $\mathcal{B}_X$  is disciplined, this could be completed to give a copy of  $S$  in  $P$  disjoint from  $Q$ . Since  $P$  is connected and intersects  $Q$  essentially, this is impossible.

*Case 3.* No annulus in  $\mathcal{B}_A$  (resp. no annulus in  $\mathcal{B}_X$ ) based on  $S$  contains an essential curve of intersection with  $Q$  (resp.  $P$ ).

In this case either there is also an annulus in  $\mathcal{B}_X$ , based on a curve in  $S$ , whose intersection with  $P$  contains no essential curve, and we are done by the previous case, or every annulus in  $\mathcal{B}_X$  based on curves in  $S$  intersects  $P$  in at least one essential simple closed curve. Then we are done by Case 2.

*Case 4.* There are curves  $c \in \mathcal{C} \cap S$  and  $c' \in \mathcal{C}' \cap S$  which intersect in a single point, and, of the two annuli  $\mathcal{A}$  and  $\mathcal{A}'$  based on  $c$  and  $c'$  in  $\mathcal{B}_A$ , one intersects  $Q$  in an essential closed curve and the other doesn't.

Say  $\mathcal{A}$  doesn't and  $\mathcal{A}'$  does. Then the subannulus  $\mathcal{A}''$  of  $\mathcal{A}'$  cut off by an outermost curve of intersection with  $Q$  is a spanning annulus of  $X$ . Now, as in Case 1, the intersection of the annuli  $\mathcal{A}$  and  $\mathcal{A}''$  contains the required arc.

The proof then proceeds as follows: Let  $\mathcal{C}_{A+}$  (resp.  $\mathcal{C}_{A-}$ ) be the set of curves in  $\mathcal{C} \cup \mathcal{C}'$  so that the annulus in  $\mathcal{B}_A$  based on the curve does (resp. does not) intersect  $Q$  in an essential simple closed curve. If either set is empty we're done by Case 2 or 3. Together they comprise all of  $\mathcal{C} \cup \mathcal{C}'$ , a connected set. So there is a (necessarily transverse) intersection point of  $\mathcal{C}_{A+}$  with  $\mathcal{C}_{A-}$ , and Case 4 applies.  $\diamond$

**Definition 7.3.** For Heegaard splittings  $A \cup_P B$  and  $X \cup_Q Y$ , the oriented splitting surfaces  $P$  has spinal intersection with the oriented splitting surface  $Q$  over  $\partial_0 M$  if

1.  $P$  and  $Q$  are in general position except at a finite number of saddle tangencies,
2. at the points where  $P$  and  $Q$  are tangent the orientations of  $P$  and  $Q$  in  $M$  coincide,
3. the resulting 1-complex  $\kappa = P \cap Q$  contains a spine of  $Q$ , and
4. for each component  $S$  of  $\partial_0 M$  there is an arc from  $\kappa$  to  $S$  in  $A \cap X$  which is vertical in both  $A$  and  $X$ .

**Proposition 7.4.** *Suppose  $A \cup_P B$  and  $X \cup_Q Y$  are strongly irreducible Heegaard splittings of the same manifold  $M$ , with  $\partial_- A = \partial_- X = \partial_0 M$  and  $\partial_- B = \partial_- Y = \partial_1 M$ . Suppose  $P$  and  $Q$  are of genus  $p \leq q$  respectively. Then after at most  $7q + 4p + \chi(\partial M) - |\partial M| - 11$  stabilizations of  $P$ ,  $P$  can be isotoped to have spinal intersection with  $Q$  over one of  $\partial_0 M$  or  $\partial_1 M$  (in fact over  $\partial_1 M$  if  $\partial_1 M$  is empty).*

*Proof.* By 3.1 one of  $P$  or  $Q$  (say  $Q$ , which will give the higher bound) can be isotoped so as to satisfy the hypotheses of 6.2. The last condition of 3.1 further ensures that for one of  $X$  or  $Y$ , say  $X$ ,  $P \cap X$  is incompressible in  $X$ . Then 2.11 guarantees that  $Q$  satisfies the hypotheses of 7.2, so that for each component  $S$  of  $\partial_0 M$ , there is an arc from  $P \cap Q$  to  $S$  in  $A \cap X$  which is vertical in both  $A$  and  $X$ . This is unaffected by the  $7q + 4p + \chi(\partial M) - |\partial M| - 11$  stabilizations of  $P$  needed,

according to 6.2, to make  $P$  spinal with respect to  $Q$ . Then [RS1, 11.2] describes how to isotope the stabilized  $P$  to make it have spinal intersection with  $Q$  over  $\partial_0 M$  (and also over  $\partial_1 M$  if  $\partial_1 M$  is empty, since for this the last condition of 7.3 is moot and no vertical arcs are required).  $\diamond$

**Lemma 7.5.** *If  $P$  has spinal intersection with  $Q$ , then there are neighborhoods  $\eta_P(\kappa)$  and  $\eta_Q(\kappa)$  of  $\kappa$  in  $P$  and  $Q$  respectively so that, after a small ambient isotopy of  $M$  rel  $\kappa$ ,  $\eta_P(\kappa) = \eta_Q(\kappa)$ .*

*Proof.* See [RS1, 11.3].  $\diamond$

**Proposition 7.6.** *Suppose  $P$  and  $Q$  are oriented splitting surfaces of genus  $p$  and  $q$  respectively and  $P$  has spinal intersection with  $Q$  over  $\partial_0 M$ . Let  $q'$  be the minimal number of defining 2-disks for  $X$ . That is,  $q' = q$  if  $\partial_0 M = \emptyset$  and  $q' = q - 1 + \chi(\partial_0 M)$  if  $\partial_0 M \neq \emptyset$ . Then  $P$  and  $Q$  have a common stabilization of genus  $p + q'$ .*

*Proof.* The case in which  $\partial_0 M = \emptyset$  is [RS1, 11.4], so we'll assume  $\partial_0 M \neq \emptyset$ . Following the previous lemma, isotope a neighborhood  $\eta_P(\kappa)$  of  $\kappa = P \cap Q$  in  $P$  so that it coincides with a neighborhood  $\eta_Q(\kappa)$  of  $\kappa$  in  $Q$ . For each component  $S$  of  $\partial_0 M$  let  $x_S$  be the end point in  $Q$  of the vertical arc  $\alpha_S$  in  $A \cap X$  given by 7.2 for  $S$ . It is easy to find a graph  $\Xi \subset Q$  so that the union of  $\Xi$  and the vertical arcs  $\{\alpha_S\}$  is a spine  $\Xi_+$  for  $X$  and  $\{x_S | S \in \partial_0 M\}$  are the only vertices of  $\Xi$ . Then  $\Xi$  can be isotoped rel  $\{x_S\}$  into  $\eta_Q(\kappa) = \eta_P(\kappa) \subset P$ . Now push a small interior arc of each of the  $q'$  edges of  $\Xi$  into  $B$  and off of  $P$ . The union  $H$  of  $A$  and a relative regular neighborhood of these arcs in  $B$  is a compression body obtained by adding  $q'$  trivial handles to  $A$ , so  $\partial_+ H$  is a  $q'$ -fold stabilization of  $P$ .

Now imagine pulling more of each arc of  $\Xi$  into  $B$  until all of  $\Xi$  except the vertices  $\{x_S\}$  have been pulled into  $B$ . This defines an isotopy of  $H$  after which  $R = \partial_+ H$  is apparently also a Heegaard splitting of the compression body  $Y_+$ , homeomorphic to  $Y$ , obtained by removing a neighborhood of  $\Xi_+$  from  $M$ . Indeed, one component of  $Y_+ - R$  is just  $B$  with  $q'$  boundary parallel arcs removed. The other can be  $\partial$ -reduced along a complete family of defining disks for  $P$  to become just  $R \times I$ . Any Heegaard splitting of a compression body is just a stabilization of the boundary [ST1, 2.7], so  $\partial_+ H$  is then also a stabilization of  $Q = \partial_+ Y$ .  $\diamond$

**Theorem 7.7.** *Suppose  $A \cup_P B$  and  $X \cup_Q Y$  are strongly irreducible Heegaard splittings of the same manifold  $M$ , with  $\partial_- A = \partial_- X = \partial_0 M \neq \emptyset$  and  $\partial_- B = \partial_- Y = \partial_1 M$  and  $\chi(\partial_1 M) \leq \chi(\partial_0 M)$  if  $\partial_1 M \neq \emptyset$ . Suppose  $P$  and  $Q$  are of genus  $p \leq q$  respectively. Then there is a genus  $8q + 5p + \chi(\partial M) + \chi(\partial_0 M) - |\partial M| - 12$  Heegaard splitting of  $M$  which stabilizes both  $A \cup_P B$  and  $X \cup_Q Y$ . (Or genus  $8q + 5p + \chi(\partial M) - |\partial M| - 11$  if  $\partial_1 M$  is empty.)*

*Proof.* 7.4 shows that, after at most  $7q + 4p + \chi(\partial M) - |\partial M| - 11$  stabilizations of  $P$  (raising the genus of  $P$  to  $7q + 5p + \chi(\partial M) - |\partial M| - 11$ ),  $P$  has spinal intersection with  $Q$  over one of  $\partial_0 M$  or  $\partial_1 M$  (over  $\partial_1 M$  if  $\partial_1 M$  is empty). Then 7.6 says that the new  $P$  and the old  $Q$  have a common stabilization of genus at most  $8q + 5p + \chi(\partial M) + \chi(\partial_0 M) - |\partial M| - 12$ , or genus  $8q + 5p + \chi(\partial M) - |\partial M| - 11$  if  $\partial_1 M = \emptyset$ .  $\diamond$

## REFERENCES

- [CG] A. Casson and C. McA. Gordon, Reducing Heegaard splittings, *Topology and its Applications*, **27** (1987), 275-283. MR **89c**:57020
- [C] J. Cerf, *Sur les difféomorphismes de la sphère de dimension trois* ( $\Gamma_4 = 0$ ), Lecture Notes in Math., **53** Springer-Verlag, Berlin and New York, 1968. MR **37**:4824
- [F] C. Frohman, Minimal surfaces and Heegaard splittings of the three-torus, *Pac. Jour. Math.*, **124** (1986), 119-130. MR **87j**:57011
- [Ha] W. Haken, Some results on surfaces in 3-manifolds, *Studies in Modern Topology*, Math. Assoc. Am., Prentice Hall, 1968, 34-98. MR **36**:7118
- [Jo] K. Johannson, *Topology and Combinatorics of 3-Manifolds*, Lecture Notes in Math, **1599** Springer-Verlag, Berlin and New York, 1995. CMP 97:09
- [RS1] H. Rubinstein and M. Scharlemann, Comparing Heegaard splittings of non-Haken 3-manifolds, *Topology* **35** (1996), 1005-1026. CMP 96:17
- [RS2] H. Rubinstein and M. Scharlemann, Transverse Heegaard splittings, *Michigan Math. J.* **49** (1997), 69-83. CMP 97:10
- [Sch] J. Schultens, The stabilization problem for Heegaard splittings of Seifert fibered spaces, *Topology and its Applications* **73** (1996), 133-139. CMP 97:03
- [ST1] M. Scharlemann and A. Thompson, Heegaard splittings of  $(\text{surface}) \times I$  are standard, *Math. Ann.*, **295** (1993), 549-564. MR **94b**:57020
- [ST2] M. Scharlemann and A. Thompson, Thin position for 3-manifolds, *AMS Contemporary Math.* 164 (1994) 231-238. MR **95e**:57032
- [W] F. Waldhausen, Heegaard-Zerlegungen der 3-Sphäre, *Topology*, **7** (1968), 195-203. MR **37**:3576

DEPARTMENT OF MATHEMATICS, UNIVERSITY OF MELBOURNE, PARKVILLE, VIC 3052, AUSTRALIA

*E-mail address:* rubin@undoe.mu.oz.au

DEPARTMENT OF MATHEMATICS, UNIVERSITY OF CALIFORNIA, SANTA BARBARA, CALIFORNIA 93106

*E-mail address:* mgscharl@math.ucsb.edu