

Homework 1

Week 5

Mathcamp 2011

Attempt the problems that seem interesting! Easier exercises are marked with $(-)$ signs; harder ones are marked by $(*)$. Open questions are denoted by writing $(**)$, as they are presumably quite hard.

- Hello!
 - How are you?
- In the P_4 -based graph we discussed in class, we assumed the piffle chose to go left with probability $1/2$ and right with probability $1/2$. Suppose it instead chooses to go left with probability p and right with probability $1 - (1/p)$: what probabilities does this correspond to in our random walk?
- Can you create an interpretation of the above random walk using an electrical network? Why or why not?
- $(*)$ A tiling of a rectangle by squares is a way to divide the area of a rectangle into finitely many squares. Prove, using electrical networks, that if any rectangle can be tiled by squares then the ratio of two neighboring sides of the rectangle is rational.

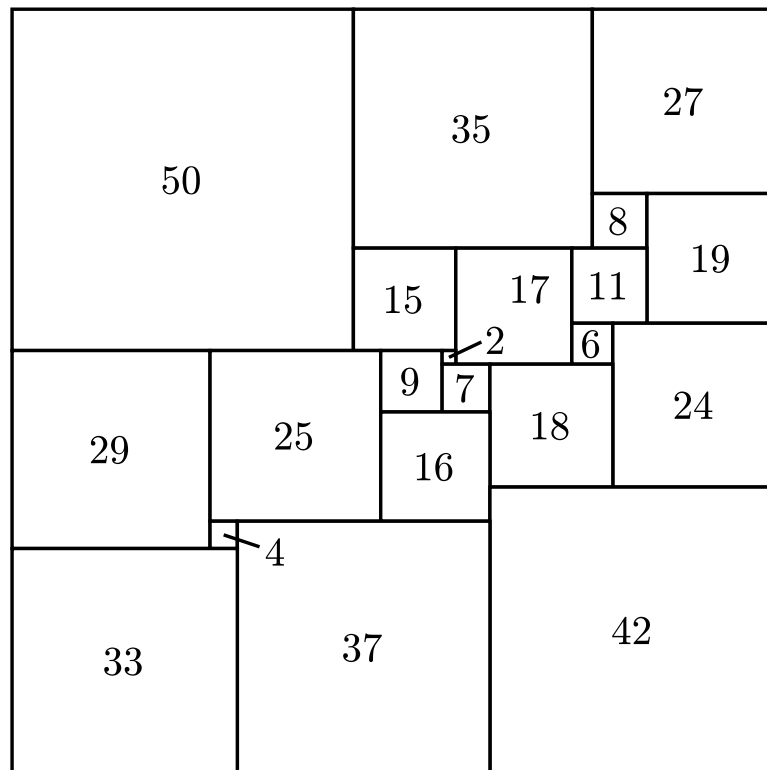

5. (Things We Will Mention But Not Prove Tomorrow:) Suppose that we have a sequence of resistors linked together in parallel, i.e. as below:

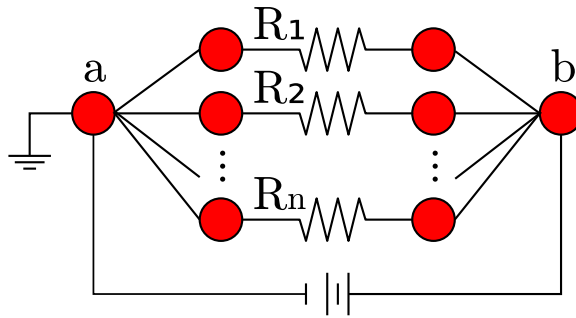

Show that if there's one unit of voltage potential difference between a and b , the current leaving the source node b is $1/C_a$: i.e. the "resistance" of this entire circuit is $C_a = \sum_{i=1}^n \frac{1}{R_i}$.

6. Similarly, prove that if we have a sequence of resistors linked together in series,

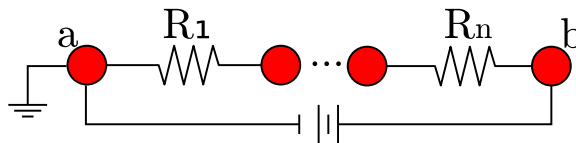

the resistance of the total circuit is $\sum_{i=1}^n R_i$.